

**Beschreibung der Datenstruktur von b2bOptic
(Version 1.5.0 Beta)**

Table of Contents

Foreword	0
Part I introduction	5
1 Lens-manufacturer	5
Part II XML-Struktur	7
1 ToDo-Liste	7
2 overview	8
3 rootelement "b2bOptic"	10
4 Simple Types	11
AdditionRefractionMethod	12
AngleDimension	13
ApplianceWeightUnity	14
BevelPosType	15
BevelTypes	16
ChamferIntensity	17
ChamferPos	18
CoatingTypes	19
EdgingType	20
FittingPlace	21
FrameMaterials	22
Gender	23
HeightReferences	24
MsgStates	25
MsgSteps	26
MsgTypes	27
OCReferences	28
RCDReferences	29
Roles	30
RxDataReferences	31
Sides	32
SidesSimple	33
SoftwareTypes	34
ThicknessReferences	35
TracerBinaryFormat	36
TracerType	38
5 Complex Types	40
Account	41
Address	44
ApplianceWeight	47
Bevel	50
Centration	53
Coating	58
ContactInfo	60
CPoint	63
Curve	65
Cylinder	68

Decentration	70
Diameter	72
DrillHoles	74
Edging	77
Fitting	79
Frame	80
FrameSize	86
GeometryType	89
Header	94
IProfilerData	98
IProfilerMap	102
IProfilerResult	105
Item	109
Lens	114
Pair	119
Patient	122
PPoint	126
Prism	128
ProductCatalog	130
RXDataTypeSimple	132
RXDataType	134
RxDataTypeFarNear	137
RxDataTypeFn	139
RXDataType4SL	141
Shape	144
Software	147
StockLens	149
TimeStamps	152
TracerData	154
Zernikes	156
Zernikes7	159
Zernikes8	166
Zernikes9	168
Zernikes10	171
Zernikes11	174
Zernikes12	177
Part III XSD - Versionen	181
1 Version 1.2.3	181
2 Änderungen von Version 1.2.3 nach 1.5.0	204
3 Version 1.5.0 Beta	211
Index	227

Chapter



1 introduction

1.1 Lens-manufacturer

the following manufacturers are able to receive data in this fileformat.

CZ = Carl Zeiss

ROD = Rodenstock

SEI = Seiko

Chapter



2 XML-Struktur

2.1 ToDo-Liste

Beispiel-Bestellungen.

2.2 overview

[Rotelement b2bOptic](#)

simple types

[AdditionRefractionMethod](#)

[AngleDimension](#)

[BevelPosType](#)

[BevelTypes](#)

[EdgingType](#)

[ChamferIntensity](#)

[ChamferPos](#)

[CoatingTypes](#)

[EdgingType](#)

[FrameMaterials](#)

[Gender](#)

[HeightReferences](#)

[MsgStates](#)

[MsgSteps](#)

[MsgTypes](#)

[OCReferences](#)

[Roles](#)

[Sides](#)

[SidesSimple](#)

[SoftwareTypes](#)

[ThicknessReferences](#)

[TracerBinaryFormat](#)

[TracerType](#)

complex types

[Account](#)

[Address](#)

[Bevel](#)

[Centration](#)

[Coating](#)

[ContactInfo](#)

[CPoint](#)

[Curve](#)

[Cylinder](#)

[Decentration](#)

[Diameter](#)

[DrillHoles](#)

[Edging](#)

[Frame](#)

[FrameSize](#)

[GeometryType](#)

[Header](#)

[IProfilerData](#)

[IProfilerMap](#)

[IProfilerResult](#)

[Item](#)

[Lens](#)

[Pair](#)

[Patient](#)

[PPoint](#)
[Prism](#)
[ProductCatalog](#)
[RXDataTypeSimple](#)
[RXDataType](#)
[RXDataType4SL](#)
[Shape](#)
[Software](#)
[StockLens](#)
[TimeStamps](#)
[TracerData](#)
[Zernikes](#)
[Zernikes7](#)
[Zernikes8](#)
[Zernikes9](#)
[Zernikes10](#)
[Zernikes11](#)
[Zernikes12](#)

2.3 rootelement "b2bOptic"

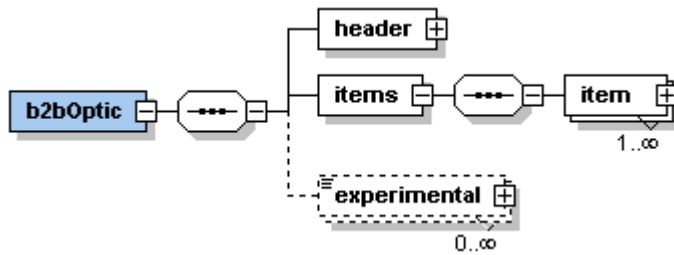

Elemente

header

type: [Header](#)
 occurs: 1
 description:

items

type: sequence of item
 occurs: 1
 description:

item

type: [Item](#)
 occurs: 1..n
 description:

experimental

type: anyType
 occurs: 0..n
 description:

XSD

```
<xs:element name="b2bOptic">
  <xs:complexType>
    <xs:sequence>
      <xs:element name="header" type="Header"/>
      <xs:element name="items">
        <xs:complexType>
          <xs:sequence>
            <xs:element name="item" type="Item" maxOccurs="unbounded"
          </xs:sequence>
        </xs:complexType>
      </xs:element>
      <xs:element name="experimental" type="xs:anyType" minOccurs="0" maxOccurs="unbounded"
    </xs:sequence>
  </xs:complexType>
</xs:element>
```

2.4 Simple Types

simple types

[AngleDimension](#)

[BevelPosType](#)

[BevelTypes](#)

[EdgingType](#)

[FrameMaterials](#)

[Gender](#)

[HeightReferences](#)

[MsgStates](#)

[MsgSteps](#)

[MsgTypes](#)

[OCReferences](#)

[Roles](#)

[Sides](#)

[SoftwareTypes](#)

[ThicknessReferences](#)

[TracerBinaryFormat](#)

2.4.1 AdditionRefractionMethod

Used in

[Patient](#)

Simple Type

type: string

possible values: FRONT
BACK
ASWORN
PHOROPTER

description:

XSD

```
<xs:simpleType name="AdditionRefractionMethod">
  <xs:restriction base="xs:string">
    <xs:enumeration value="FRONT" />
    <xs:enumeration value="BACK" />
    <xs:enumeration value="ASWORN" />
    <xs:enumeration value="PHOROPTER" />
  </xs:restriction>
</xs:simpleType>
```

2.4.2 AngleDimension

Used in
[Frame PPoint](#)

Simple Type

type: string

possible values: DEG
RAD
MM

description: (todo: Wann und bei wem wird RAD verwendet. Sollte RAD entfernt werden?)
ROD,ZEI,SEI: RAD ignored

XSD

```
<xs:simpleType name="AngleDimension">  
  <xs:restriction base="xs:string">  
    <xs:enumeration value="DEG" />  
    <xs:enumeration value="RAD" />  
    <xs:enumeration value="MM" />  
  </xs:restriction>  
</xs:simpleType>
```

2.4.3 ApplianceWeightUnity

Used in

[ApplianceWeight](#)

Simple Type

type: string

possible values: PERCENT
VALUE

description:

XSD

```
<xs:simpleType name="ApplianceWeightUnity">
  <xs:restriction base="xs:string">
    <xs:enumeration value="PERCENT"/>
    <xs:enumeration value="VALUE"/>
  </xs:restriction>
</xs:simpleType>
```

2.4.4 BevelPosType

Used in

[Bevel](#)

Simple Type

type: string

possible values: AUTO
FRONT
BACK
RELATION
FRAMECURVATURE
FRAMEBASE

description: AUTO: LagDe: Optimiert nach Fassungsscheibenwinkel und Basiskurve.
Freilaufende Facette.

FRONT: unity = mm -> distance to front todo:Beschreibung nach Bevel

verlegen

BACK: unity = mm -> distance to back. todo:Beschreibung nach Bevel

verlegen

Glases.

RELATED: unity = percente -> Prozentualer Abstand zur Frontseite des

FRAMECURVATURE: todo: Beschreibung folgt

FRAMEBASE: todo: Beschreibung folgt

XSD

```
<xs:simpleType name="BevelPosType">
  <xs:restriction base="xs:string">
    <xs:enumeration value="AUTO"/>
    <xs:enumeration value="FRONT"/>
    <xs:enumeration value="BACK"/>
    <xs:enumeration value="RELATION"/>
    <xs:enumeration value="FRAMECURVATURE"/>
    <xs:enumeration value="FRAMEBASE"/>
  </xs:restriction>
</xs:simpleType>
```

2.4.5 BevelTypes

Used in

[Bevel](#)

Simple Type

type: string

possible values: BEVEL LngDe:-> Entspricht Spitzfacette
FLAT
GROOVED

description:

XSD

```
<xs:simpleType name="BevelTypes">  
  <xs:restriction base="xs:string">  
    <xs:enumeration value="BEVEL"/>  
    <xs:enumeration value="FLAT"/>  
    <xs:enumeration value="GROOVED"/>  
  </xs:restriction>  
</xs:simpleType>
```

2.4.6 ChamferIntensity

Used in

[Edging](#)

Simple Type

type: string

possible values: THIN
MEDIUM
LARGE

description:

XSD

```
<xs:simpleType name="ChamferIntensity">  
  <xs:restriction base="xs:string">  
    <xs:enumeration value="THIN" />  
    <xs:enumeration value="MEDIUM" />  
    <xs:enumeration value="LARGE" />  
  </xs:restriction>  
</xs:simpleType>
```

2.4.7 ChamferPos

Used in

[Edging](#)

Simple Type

type: string

possible values: BOTH
FRONT
BACK

description:

XSD

```
<xs:simpleType name="ChamferPos">  
  <xs:restriction base="xs:string">  
    <xs:enumeration value="BOTH"/>  
    <xs:enumeration value="FRONT"/>  
    <xs:enumeration value="BACK"/>  
  </xs:restriction>  
</xs:simpleType>
```

2.4.8 CoatingTypes

Used in

[Coating](#)

Simple Type

type: string

possible values: COLOR
UV
ANTIREFLEX
HARD
CLEAN
OTHER

description:

XSD

```
<xs:simpleType name="CoatingTypes">  
  <xs:restriction base="xs:string">  
    <xs:enumeration value="COLOR" />  
    <xs:enumeration value="UV" />  
    <xs:enumeration value="ANTIREFLEX" />  
    <xs:enumeration value="HARD" />  
    <xs:enumeration value="CLEAN" />  
    <xs:enumeration value="OTHER" />  
  </xs:restriction>  
</xs:simpleType>
```

2.4.9 EdgingType

Used in

[Edging](#)

Simple Type

type: string

possible values: ROUGHING
ONSHAPE
GIVENFRAME
ORDEREDFRAME

description: ROUGHING: LngDe: Vorschliff
ONSHAPE: Mitgesendete Randungsdaten werden verwendet.
GIVENFRAME: Fassung wird vom Kunden zur Verglasung eingeschickt
ORDEREDFRAME: Gläser werden mit Fassung zusammen bestellt (Fassung des Glasherstellers)

info: CZ, SEI, ROD: ROUGHING ignored.

XSD

```
<xs:simpleType name="EdgingType">  
  <xs:restriction base="xs:string">  
    <xs:enumeration value="ROUGHING" />  
    <xs:enumeration value="ONSHAPE" />  
    <xs:enumeration value="GIVENFRAME" />  
    <xs:enumeration value="ORDEREDFRAME" />  
  </xs:restriction>  
</xs:simpleType>
```

2.4.10 FittingPlace

Used in

[Fitting](#)

Simple Type

type: string

possible values: MANUFACTURER
LAB
SHOP

description: MANUFACTURER:
LAB:
SHOP:

info:

XSD

```
<xs:simpleType name="FittingPlace">  
  <xs:restriction base="xs:string">  
    <xs:enumeration value="MANUFACTURER"/>  
    <xs:enumeration value="LAB"/>  
    <xs:enumeration value="SHOP"/>  
  </xs:restriction>  
</xs:simpleType>
```

2.4.11 FrameMaterials

Used in
[Frame](#)

Simple Type

type: string

possible values: METAL
PLASTIC
OPTYL
NYLOR
DRILLED
SPECIAL

description:

info:	SEI:	OPTYL:	Wird bei SEIKO nicht benutzt und auch nicht ausgewertet, da nichts anfangen können.
			die Randungsautomaten mit diesem Parameter
		SPECIAL	Wird für alle Sonderfassungen, die eine Sonderbehandlung wie spezielle Nutbreite, Nuttiefe oder spezielle Größenvorgaben erfordern verwendet.
			Hat (bei SEIKO) auch Auswirkungen auf die Preisermittlung für die Fernrandung.
	ROD	OPTYL: SPECIAL	Ignored Ignored
	CZ:	SPECIAL	LngDe: Wird für spezielles Material verwendet.
	Z.B. für Horn. In diesem Fall „tracerData“		wird der Wert „adjustion“, der jetzt direkt unter steht, berücksichtigt

XSD

```
<xs:simpleType name="FrameMaterials">
  <xs:restriction base="xs:string">
    <xs:enumeration value="METAL"/>
    <xs:enumeration value="PLASTIC"/>
    <xs:enumeration value="OPTYL"/>
    <xs:enumeration value="NYLOR"/>
    <xs:enumeration value="DRILLED"/>
    <xs:enumeration value="SPECIAL"/>
  </xs:restriction>
</xs:simpleType>
```

2.4.12 Gender

Used in
[Patient](#)

Simple Type

type: string

possible values: male
female

description:

XSD

```
<xs:simpleType name="Gender">  
  <xs:restriction base="xs:string">  
    <xs:enumeration value="MALE" />  
    <xs:enumeration value="FEMALE" />  
  </xs:restriction>  
</xs:simpleType>
```

2.4.13 HeightReferences

Used in
[Centration](#)

Simple Type

type:	string
possible values:	OVERBOX OVERSHAPE
description:	OVERBOX = Kastenmass OVERSHAPE = Messlinienverfahren
info:	SEI: OVERSHAPE not used

XSD

```
<xs:simpleType name="HeightReferences">  
  <xs:restriction base="xs:string">  
    <xs:enumeration value="OVERBOX" />  
    <xs:enumeration value="OVERSHAPE" />  
  </xs:restriction>  
</xs:simpleType>
```

2.4.14 MsgStates

Used in

[Header](#)

Simple Type

type: string

possible values: NEW
UPDATE
CANCEL

description:

XSD

```
<xs:simpleType name="MsgStates">  
  <xs:restriction base="xs:string">  
    <xs:enumeration value="NEW" />  
    <xs:enumeration value="UPDATE" />  
    <xs:enumeration value="CANCEL" />  
  </xs:restriction>  
</xs:simpleType>
```

2.4.15 MsgSteps

Used in
[TimeStamps](#)

Simple Type

type:	string
possible values:	CREATE TRANSFER RECEIPT
description:	CREATE: LngDe: Zeitpunkt der Erzeugung der XML-Datei. TRANSFER: LngDe: Zeitpunkt der Übertragung der XML-Datei RECEIPT: LngDe: Empfangszeit der XML-Datei
info:	TRANSFER: Ignored by CZ RECEIPT: Ignored by CZ

XSD

```
<xs:simpleType name="MsgSteps">  
  <xs:restriction base="xs:string">  
    <xs:enumeration value="CREATE" />  
    <xs:enumeration value="TRANSFER" />  
    <xs:enumeration value="RECEIPT" />  
  </xs:restriction>  
</xs:simpleType>
```

2.4.16 MsgTypes

Used in
[Header](#)

Simple Type

type:	string
possible values:	ORDER REQUEST CALCULATION VALIDATION
description:	LngDe: ORDER =Bestellung/Auftrag LngDe: REQUEST =Statusabfrage eines gesendeten Auftrages LngDe: CALCULATION =Übertragung von Glasdaten zur Berechnug LngDe: VALIDATION = Abfrage ob Bestellung möglich ist.
info:	ROD: REQUEST, CALCULATION and VALIDATION are currently ignored.
	CZ: REQUEST, CALCULATION and VALIDATION are currently ignored.
	SEI: VALIDATION are currently ignored.

XSD

```
<xs:simpleType name="MsgTypes">  
  <xs:restriction base="xs:string">  
    <xs:enumeration value="ORDER"/>  
    <xs:enumeration value="REQUEST"/>  
    <xs:enumeration value="CALCULATION"/>  
    <xs:enumeration value="VALIDATION"/>  
  </xs:restriction>  
</xs:simpleType>
```

2.4.17 OReferences

Used in

[Centration](#)

Simple Type

type: string

possible values: FAR
NEAR

description:

XSD

```
<xs:simpleType name="OReferences">  
  <xs:restriction base="xs:string">  
    <xs:enumeration value="FAR" />  
    <xs:enumeration value="NEAR" />  
  </xs:restriction>  
</xs:simpleType>
```

2.4.18 RCDReferences

Used in
[Centration](#)

Simple Type

type: string

possible values: CORNEA
FRAME

description:

info:

XSD

```
<xs:simpleType name="RCDReferences">
  <xs:restriction base="xs:string">
    <xs:enumeration value="CORNEA"/>
    <xs:enumeration value="FRAME"/>
  </xs:restriction>
</xs:simpleType>
```

2.4.19 Roles

Used in

[Header Item](#)

Simple Type

type: string

possible values: ORIGINATOR
SUPPLIER
SHIPTO
CARRIER
INVOICETO
PAIDBY
MANUFACTURER

description: ORIGINATOR LngDe: Erzeugt den Auftrag.
SUPPLIER: LngDe: Lieferant
SHIPTO: LngDe: Lieferadresse
CARRIER: LngDe: Frachtunternehmer
INVOICETO: LngDe: Rechnungsempfänger
PAIDBY: LngDe: Gezahlt von.
MANUFACTURER: LngDe: Hersteller

info: ROD: SUPPLIER,CARRIER, INVOICETO, PAIDBY, MANUFACTURER
are currently ignored
CZ: SUPPLIER,CARRIER, PAIDBY, MANUFACTURER are currently
ignored
CZ: SUPPLIER,CARRIER, INVOICETO, PAIDBY, MANUFACTURER
are currently ignored

XSD

```
<xs:simpleType name="Roles">
  <xs:restriction base="xs:string">
    <xs:enumeration value="ORIGINATOR" />
    <xs:enumeration value="SUPPLIER" />
    <xs:enumeration value="SHIPTO" />
    <xs:enumeration value="CARRIER" />
    <xs:enumeration value="INVOICETO" />
    <xs:enumeration value="PAIDBY" />
    <xs:enumeration value="MANUFACTURER" />
  </xs:restriction>
</xs:simpleType>
```

2.4.20 RxDataReferences

Used in

[RxDataTypeFarNear](#)

Simple Type

type: string

possible values: OBJECTIVE
SUBJECTIVE

description:

XSD

```
<xs:simpleType name="RxDataReferences">  
  <xs:restriction base="xs:string">  
    <xs:enumeration value="OBJECTIVE"/>  
    <xs:enumeration value="SUBJECTIVE"/>  
  </xs:restriction>  
</xs:simpleType>
```

2.4.21 Sides

Used in

[Bevel Frame](#) [IProfilerResult](#) [Item](#) [Lens](#)

Simple Type

type: string

possible values: RIGHT
LEFT
UNDEFINED

description:

info: SEI: UNDEFINED not used

XSD

```
<xs:simpleType name="Sides">  
  <xs:restriction base="xs:string">  
    <xs:enumeration value="RIGHT"/>  
    <xs:enumeration value="LEFT"/>  
    <xs:enumeration value="UNDEFINED"/>  
  </xs:restriction>  
</xs:simpleType>
```

2.4.22 SidesSimple

Used in
[Frame](#)

Simple Type

type: string

possible values: RIGHT
LEFT

description:

info:

XSD

```
<xs:simpleType name="Sides">  
  <xs:restriction base="xs:string">  
    <xs:enumeration value="RIGHT"/>  
    <xs:enumeration value="LEFT"/>  
  </xs:restriction>  
</xs:simpleType>
```

2.4.23 SoftwareTypes

Used in

[Software](#)

Simple Type

type: string

possible values: ORIGINATOR
VERIFIER
SENDER

description: ORIGINATOR: LngDe: Erzeuger der XML
VERIFIER: LngDe: Prüfsoftware
SENDER: LngDe: Sender der XML

XSD

```
<xs:simpleType name="SoftwareTypes">  
  <xs:restriction base="xs:string">  
    <xs:enumeration value="ORIGINATOR" />  
    <xs:enumeration value="VERIFIER" />  
    <xs:enumeration value="SENDER" />  
  </xs:restriction>  
</xs:simpleType>
```

2.4.24 ThicknessReferences

Used in
[GeometryType](#)

Simple Type

type: string

possible values: REDUCEWITHSHAPE
CENTER
EDGE
DRILLHOLE

description: REDUCEWITHSHAPE = MDM
CENTER = Mindestmittendicke
EDGE = Mindestranddicke
DRILLHOLE = Mindestdicke am Bohrloch

XSD

```
<xs:simpleType name="ThicknessReferences">  
  <xs:restriction base="xs:string">  
    <xs:enumeration value="REDUCEWITHSHAPE"/>  
    <xs:enumeration value="CENTER"/>  
    <xs:enumeration value="EDGE"/>  
    <xs:enumeration value="DRILLHOLE"/>  
  </xs:restriction>  
</xs:simpleType>
```

2.4.25 TracerBinaryFormat

Used in
[TracerData](#)

Simple Type

type: string

possible values: DLL Briot
 DVI
 GT3000
 MO1
 NIDEK
 OMA3.02
 PHI
 T4
 WECO

description:

additional info:

Brand	Model	Description	Interface	AdditionalInfos
BRIOT	SCANNET	Scannet 2 Shapes Reader	OMA 3,02	512 radius, with z values
ESSILOR	PHI	Essilor Phi Shapes Reader	PHI	400 radius, with 200 z values
		Essilor Phi Shapes Reader	OMA 3,02	512 radius, with z values
	KAPPA	Essilor Kappa Tracer and Blocker	PHI	400 radius, with 200 z values
		Essilor Kappa Tracer and Blocker	OMA 3,02	512 radius, with 512 z values
WECO	Trace 1/2	Old Weco Tracer	DVI?	512 Radius
		Old Weco Tracer	Nidek	1000 Radius
HOYA	GT1000	Hoya GT1000	GT3000	500 radius
			OMA 3,02	512 radius, z values has to be clarified
HOYA	GT3000	Hoya GT3000	GT3000	500 radius
			OMA 3,02	512 radius, z values has to be clarified
NIDEK	LT 900SX	LT 900 SX Shapes Reader	Nidek	1000 Radius
SCHOENE	INDO	Schoene INDO Shapes Reader	Nidek	1000 Radius

Priority	Brand	Model	Description	Interface	Information	Implemented
3	BRIOT	SCANFROM	Scanform 1 Shapes Reader	DLL	1024 radius	no
1	BRIOT	AXCEL	Blocker with Tracer	OMA 3,02	512 radius, with 512 z values	no
3	OPTRONIC	T4	Optronics T4 Shapes Reader	T4	400 radius, with 400 z values	no
1	WECO	TRACER 3	Weco Tracer 3 Shapes Reader	OMA 3,02	512 radius, with 512 z values	no
1	WECO	CAD 5	Blocker with Tracer from WECO	OMA 3,02	512 radius, with 512 z values	no
1	NIDEK	SX 9000	SX 9000 Edger	DVI	500 Radius	no
3	NIDEK	SX 7070	SX 7070 Edger	DVI	500 Radius	no
1	NIDEK	LT 900 SX	LT 900 SX Shapes Reader	DVI	500 Radius	no
3	NIDEK	LT 700 SX	LT 700 SX Shapes Reader	DVI	500 Radius	no
1	NIDEK	LT 900 SX VCA	LT 900 SX VCA Shapes Reader	OMA 3,02	1000 Radius	no
1	R.O.M.	PIETRO	FBK	NIDEK	1000 Radius	no

XSD

```

<xs:simpleType name="TracerBinaryFormat">
  <xs:restriction base="xs:string">
    <xs:enumeration value="DLL BRIOT" />
    <xs:enumeration value="DVI" />
    <xs:enumeration value="GT3000" />
    <xs:enumeration value="MO1" />
    <xs:enumeration value="NIDEK" />
    <xs:enumeration value="OMA3.02" />
    <xs:enumeration value="PHI" />
    <xs:enumeration value="T4" />
    <xs:enumeration value="WECO" />
  </xs:restriction>
</xs:simpleType>

```

2.4.26 TracerType

Used in
[TracerData](#)

Simple Type

type: string

possible values:

Hoya 3DFT
Hoya GT1000
Hoya GT3000
Hoya GT3000 OMA
Hoya UT1000
Essilor Gamma
Essilor PHI PCCOM
Essilor PHI OMA
Essilor Kappa PCCOM
Essilor Kappa OMA
National Optronics 4T
Briot ScanfomNet I
Briot ScanfomNet II
Weco 3DFT+
Weco Trace II
Weco Trace III
Nidek LT700
Nidek LT900
Nidek LT900 OMA
Nidek LT1000
Indo NDK
Indo OMA
Topcon FR50
Takubomatic FD80
Unknown

description:

XSD

```
<xs:simpleType name="TracerType">  
  <xs:restriction base="xs:string">  
    <xs:enumeration value="Hoya 3DFT" />  
    <xs:enumeration value="Hoya GT1000" />  
    <xs:enumeration value="Hoya GT3000" />  
    <xs:enumeration value="Hoya GT3000 OMA" />  
    <xs:enumeration value="Hoya UT1000" />  
    <xs:enumeration value="Essilor Gamma" />  
    <xs:enumeration value="Essilor PHI PCCOM" />  
    <xs:enumeration value="Essilor PHI OMA" />  
    <xs:enumeration value="Essilor Kappa PCCOM" />  
    <xs:enumeration value="Essilor Kappa OMA" />  
    <xs:enumeration value="National Optronics 4T" />  
  </xs:restriction>  
</xs:simpleType>
```

```
<xs:enumeration value="Briot ScanfomNet I" />
<xs:enumeration value="Briot ScanfomNet II" />
<xs:enumeration value="Weco 3DFT+" />
<xs:enumeration value="Weco Trace II" />
<xs:enumeration value="Weco Trace III" />
<xs:enumeration value="Nidek LT700" />
<xs:enumeration value="Nidek LT900" />
<xs:enumeration value="Nidek LT900 OMA" />
<xs:enumeration value="Nidek LT1000" />
<xs:enumeration value="Indo NDK" />
<xs:enumeration value="Indo OMA" />
<xs:enumeration value="Topcon FR50" />
<xs:enumeration value="Takubomatic FD80" />
<xs:enumeration value="Unknown" />
</xs:restriction>
</xs:simpleType>
```

2.5 Complex Types

complex types

[Account](#)
[Address](#)
[Bevel](#)
[Centration](#)
[Coating](#)
[ContactInfo](#)
[CPoint](#)
[Curve](#)
[Cylinder](#)
[Cylinder](#)
[Decentration](#)
[Diameter](#)
[DrillHoles](#)
[Edging](#)
[Frame](#)
[FrameSize](#)
[GeometryType](#)
[Header](#)
[IProfilerData](#)
[IProfilerMap](#)
[IProfilerResult](#)
[Item](#)
[Lens](#)
[Pair](#)
[Patient](#)
[PPoint](#)
[Prism](#)
[ProductCatalog](#)
[RXDataType](#)
[RXDataType4SL](#)
[Shape](#)
[Software](#)
[StockLens](#)
[TimeStamps](#)
[TracerData](#)
[Zernikes](#)
[Zernikes7](#)
[Zernikes8](#)
[Zernikes9](#)
[Zernikes10](#)
[Zernikes11](#)
[Zernikes12](#)

2.5.1 Account

Used in

[Header Item Pair](#)

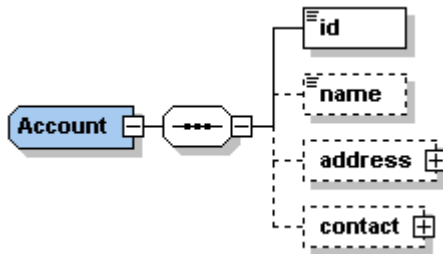

Elemente

id

type: string

attribute: memberShipID (Type long, default=1)

occurs: 1

description: (LngDe) Kundennummer

info: (LngDe) CZ: memberShipID -> Zusatz zur Kundennummer bei Zeiss. Standard "Zeiss" verwenden.

Wird verwendet um die Kundennummern von Zeiss, Sola und AO beizubehalten.

1=Zeiss

2=Sola

3=AO

name

type: string

occurs: 0..1

description:

info: CZ: ignored

adress

type: [Address](#)

occurs: 0..1

description:

info: CZ: ignored

contact

type: [ContactInfo](#)

occurs: 0..1

description:

info: CZ: ignored

XSD

```
<xs:complexType name="Account">
```

```
<xs:sequence>
  <xs:element name="id">
    <xs:complexType>
      <xs:simpleContent>
        <xs:extension base="xs:string">
          <xs:attribute name="memberShipID" type="xs:long"
use="optional" default="1"/>
        </xs:extension>
      </xs:simpleContent>
    </xs:complexType>
  </xs:element>
  <xs:element name="name" type="xs:string" minOccurs="0"/>
  <xs:element name="address" type="Address" minOccurs="0"/>
  <xs:element name="contact" type="ContactInfo" minOccurs="0"/>
</xs:sequence>
</xs:complexType>
```

2.5.2 Address

Used in

[Account](#)

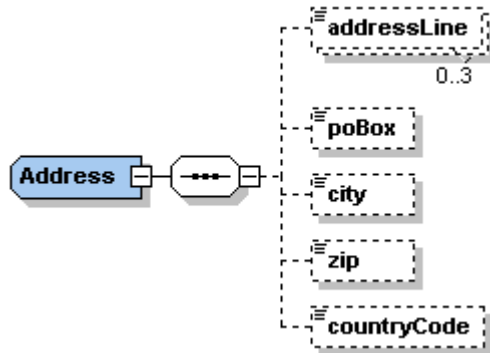

Elemente

addressLine

type: string

occurs: 0..3

description:

poBox

type: string

occurs: 0..1

description:

city

type: string

occurs: 0..1

description:

zip

type: string

occurs: 0..1

description:

countryCode

type: string

occurs: 0..1

description:

XSD

```
<xs:complexType name="Address">
  <xs:sequence>
    <xs:element name="addressLine" type="xs:string" minOccurs="0" maxOccurs="3" />
    <xs:element name="poBox" type="xs:string" minOccurs="0" />
  
```

```
<xs:element name="city" type="xs:string" minOccurs="0"/>
<xs:element name="zip" type="xs:string" minOccurs="0"/>
<xs:element name="countryCode" type="xs:string" minOccurs="0"/>
</xs:sequence>
</xs:complexType>
```

2.5.3 ApplianceWeight

Used in

[Patient](#)

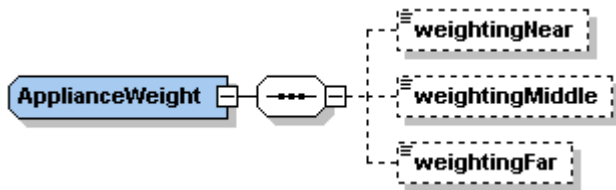

Attribute

applianceWeightUnity

type: [ApplianceWeightUnity](#)

use: required

description:

info:

Elemente

weightingNear

type: float

occurs: 0..1

description:

weightingMiddle

type: float

occurs: 0..1

description:

weightingFar

type: float

occurs: 0..1

description:

XSD

```
<xs:complexType name="ApplianceWeight">
  <xs:sequence>
    <xs:element name="weightingNear" type="xs:float" minOccurs="
0"/>
    <xs:element name="weightingMiddle" type="xs:float" minOccurs
="0"/>
    <xs:element name="weightingFar" type="xs:float" minOccurs="0
"/>
  </xs:sequence>
</xs:complexType>
```

```
<xs:attribute name="applianceWeightUnity" type="
ApplianceWeightUnity" use="required"/>
</xs:complexType>
```

2.5.4 Bevel

Used in

[Edging](#)

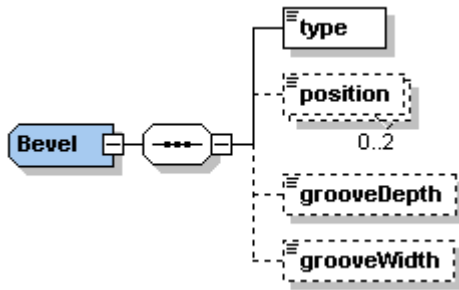

Elemente

type

type: [BevelTypes](#)

occurs: 1

description:

position

type: float

unity: mm / % / dpt

attribute: posType ([BevelPosType](#))

attribute: side ([Sides](#))

occurs: 0..2

description:

info: SEI: FRONT/BACK: Werte von 0,1mm bis 2,00 mm

SEI: RELATED: Werte von 30% bis 70%

grooveDepth

type: float

unity: mm

occurs: 0..1

description:

info: CZ: ignored

grooveWidth

type: float

unity: mm

occurs: 0..1

description:

info: CZ: (LngDe) Rillen Normal 0,6 Rillen Breit 1,2

XSD

```
<xs:complexType name="Bevel">
  <xs:sequence>
    <xs:element name="type" type="BevelTypes"/>
    <xs:element name="position" minOccurs="0" maxOccurs="2">
      <xs:complexType>
        <xs:simpleContent>
          <xs:extension base="xs:float">
            <xs:attribute name="posType" type="BevelPosType
" use="optional" default="AUTO"/>
            <xs:attribute name="side" type="Sides" use="
optional"/>
          </xs:extension>
        </xs:simpleContent>
      </xs:complexType>
    </xs:element>
    <xs:element name="grooveDepth" type="xs:float" minOccurs="0"/>
    <xs:element name="grooveWidth" type="xs:float" minOccurs="0"/>
  </xs:sequence>
</xs:complexType>
```

2.5.5 Centration

Used in

[Lens](#)

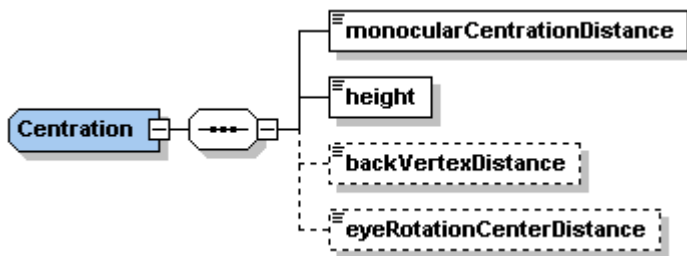

Elemente

monocularCentrationDistance

type: float

unity: mm

attribute: reference ([OCReferences](#))

occurs: 1

description: monokularer Zentrierabstand Dies entspricht dem Wert z der Zentrierdaten in der folgenden Graphik Rechts / Links wird über „lens“ Attribut „side“ gesteuert. Über das Attribut „reference“ wird der Bezug des monokularen Zentrierabstands festgelegt.
Bei „FAR“ bezieht er sich auf den Fernbezugspunkt P(R/L),
bei NEAR auf den Nahbezugspunkt N(R/L).

info: CZ: Attribut reference: Currently only FAR supported, NEAR will be ignored!

height

type: float

unity: mm

attribute: reference ([OCReferences](#))

attribute: referenceHeight ([HeightReferences](#))

occurs: 1

description: Höhe des Fernbezugspunkt Y(R/L) oder Nahtteilhöhe „Height“ ist doppeldeutig und die Bedeutung wird über das zugehörige Attribut „reference“ gesteuert.

Attribut reference:

FAR: in „height“ steht die Höhe des Fernbezugspunktes, in der Zeichnung oben als Y(R/L) zu sehen. Dies ist bei Einstärken- und Gleitsichtgläsern der Fall.

NEAR: in „height“ steht die Nahtteilhöhe, in der Zeichnung unten als hL zu sehen. Bei Bifo/Trifoggläsern wird in der Regel statt der Höhe des Fernbezugspunktes die Nahtteilhöhe vom gefordert.

Attribut referenceHeight: Werte: „OVERBOX“ und „OVERSHAPE“.

Bei „OVERBOX“ wird die Höhe von der Box aus gemessen, wie beide Zeichnungen zeigen.

Bei „OVERSHAPE“ wird die Höhe von der Fassung aus gemessen (Messliniensystem) und

durch zwar bei Einstärken- und Gleitsichtgläsern von der Stelle an der die Senkrechte
den Fernbezugspunkt die Fassung kreuzt und bei Bifo- Trifogläsern wo die
Senkrechte durch die Mitte des Nahteils bzw. durch den höchsten Punkt des Nahteils die
Fassung kreuzt.

info: CZ: Attribut reference: FAR -> Y Near -> H

backVertexDistance

type: float
unity: mm
occurs: 0..1
description: Hornhautscheitelabstand

eyeRotationCenterDistance

type: float
unity: mm
attribute: reference ([RCDDReferences](#)) - required
occurs: 0..1
description: "Abstand Augendrehpunkt zum Referenzpunkt (Attribut)"

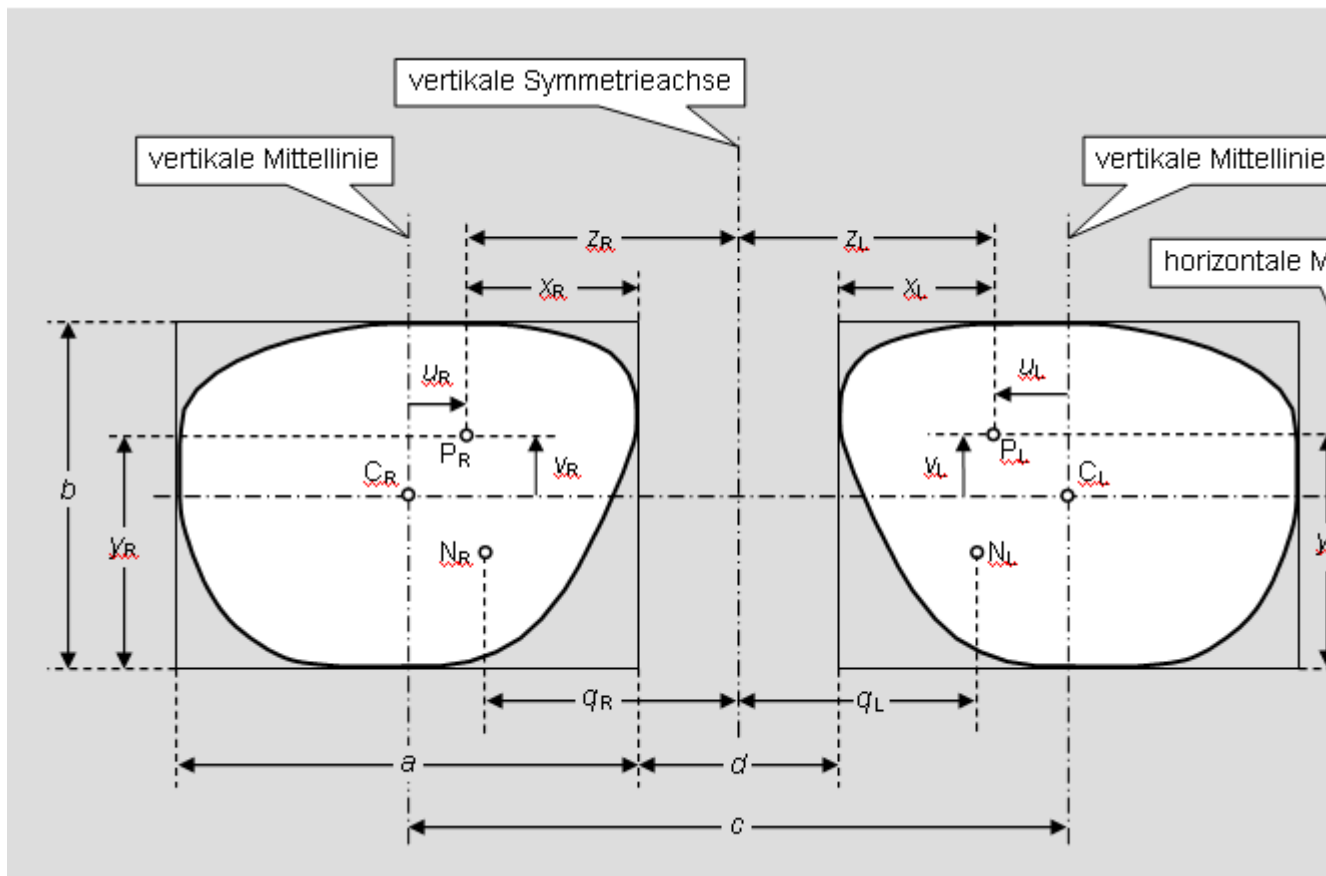

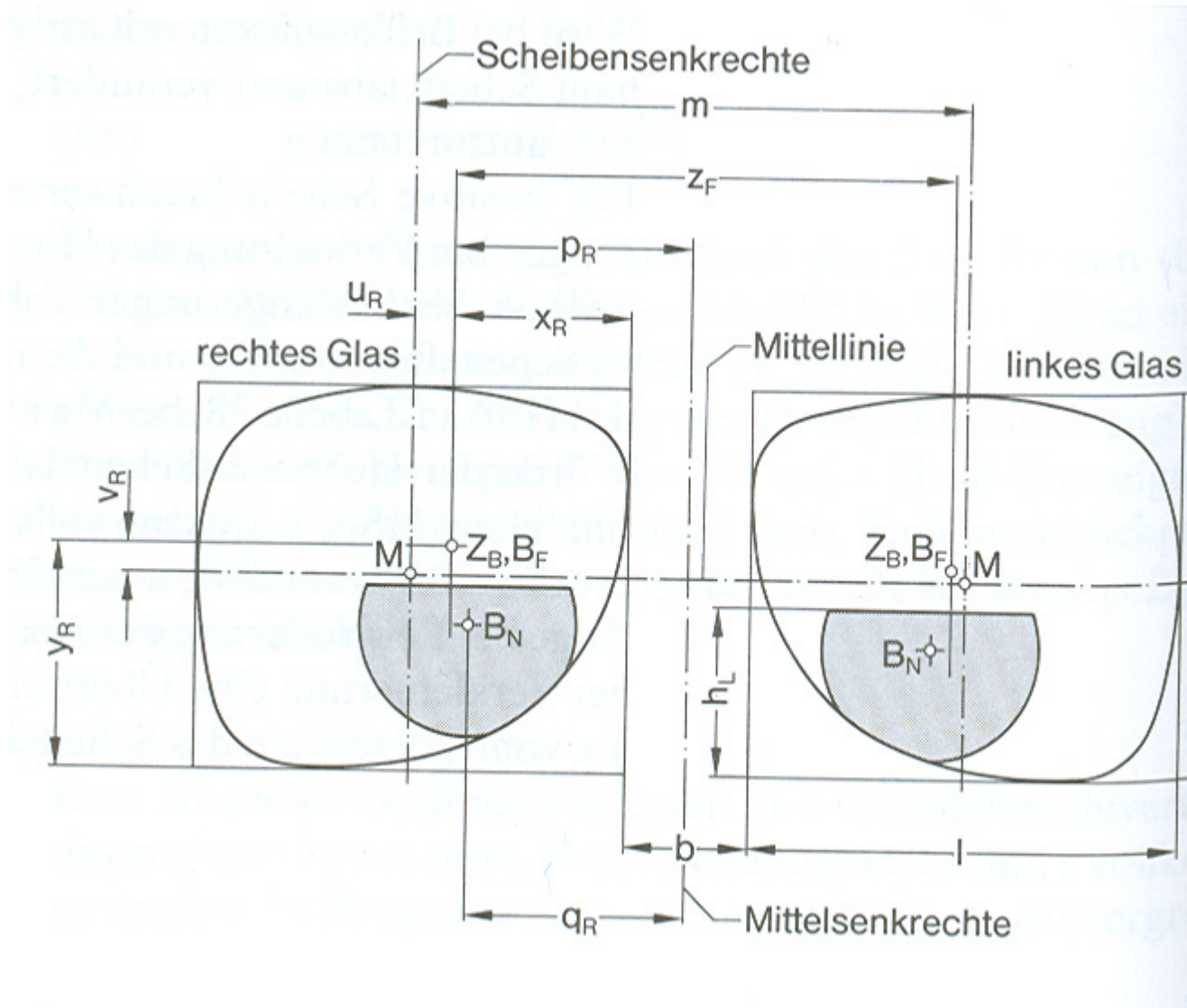

XSD

```

<xs:complexType name="Centration">
  <xs:sequence>
    <xs:element name="monocularCentrationDistance">
      <xs:complexType>
        <xs:simpleContent>
          <xs:extension base="xs:float">
            <xs:attribute name="reference" type="
  </xs:extension>
  </xs:simpleContent>
  </xs:complexType>
</xs:element>
<xs:element name="height">
  <xs:complexType>
    <xs:simpleContent>
      <xs:extension base="xs:float">

```

```
OCReferences" use="required" />
HeightReferences" use="required" />
</xs:extension>
</xs:simpleContent>
</xs:complexType>
</xs:element>
<xs:element name="backVertexDistance" minOccurs="0">
  <xs:complexType>
    <xs:simpleContent>
      <xs:extension base="xs:float" />
    </xs:simpleContent>
  </xs:complexType>
</xs:element>
</xs:sequence>
</xs:complexType>
```

2.5.6 Coating

Used in

[Lens](#) [StockLens](#)

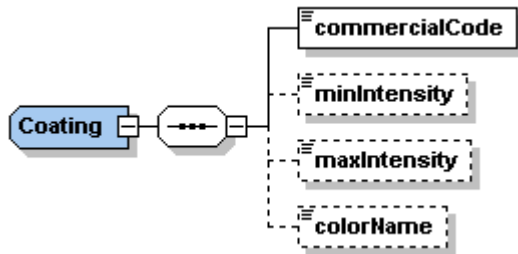

Attribute

coatingType

type: CoatingTypes

use: required

description:

info: LngDe:

- Verwendet wird mindestens COLOR bei Farben, für alles andere OTHER.
- Werden die Daten doch ausgefüllt legt man bei Mehrschichten folgende Priorität fest: ANTIREFLEX, COLOR, HARD, CLEAN, UV, OTHER .

Elemente

commercialCode

type: string

occurs: 1

description:

minIntensity

type: integer

unity: percentage

occurs: 0..1

description: Minimum color intensity for tinting as a percentage

info: CZ: ignored

maxIntensity

type: integer

unity: percentage

occurs: 0..1

description: Maximum color intensity for tinting as a percentage

info: CZ: ignored

colorName

type: String

occurs:	0..1
description:	LngDe: Beschreibende Bezeichnung einer Farbe. Nur gültig in Verbindung des entsprechenden EDV-Codes für Freie Farbe des Herstellers.
info:	CZ: ignored

XSD

.

2.5.7 ContactInfo

Used in

[Account](#)

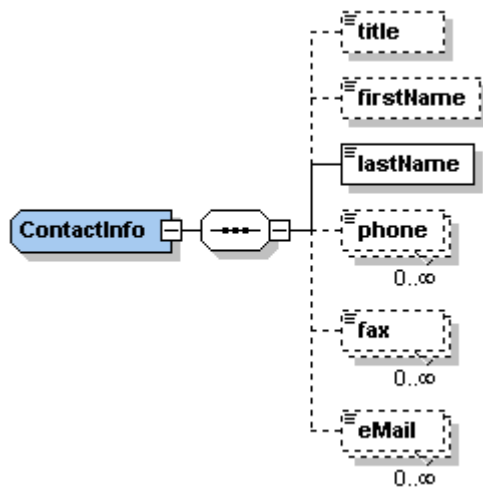

Elemente

title

type: string

occurs: 0..1

description:

firstName

type: string

occurs: 0..1

description:

lastName

type: string

use: required

occurs: 1

description:

phone

type: string

occurs: 0..n

description:

fax

type: string

occurs: 0..n

description:

eMail

type: string

occurs: 0..n
description:

XSD

```
<xs:complexType name="ContactInfo">
  <xs:sequence>
    <xs:element name="title" type="xs:string" minOccurs="0" />
    <xs:element name="firstName" type="xs:string" minOccurs="0" />
    <xs:element name="lastName" type="xs:string" />
    <xs:element name="phone" type="xs:string" minOccurs="0" maxOccurs="unbounded" />
  </xs:sequence>
  <xs:element name="fax" type="xs:string" minOccurs="0" maxOccurs="unbounded" />
  <xs:element name="eMail" type="xs:string" minOccurs="0" maxOccurs="unbounded" />
</xs:complexType>
```

2.5.8 CPoint

Used in
[Shape](#)

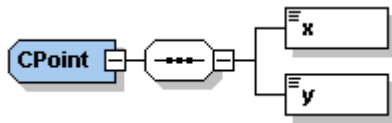

Elemente

x

type: float
unity: mm
occurs: 1
description:

y

type: float
unity: mm
occurs: 1
description:

XSD

```
<xs:complexType name="CPoint">
  <xs:sequence>
    <xs:element name="x" type="xs:float"/>
    <xs:element name="y" type="xs:float"/>
  </xs:sequence>
</xs:complexType>
```

2.5.9 Curve

Used in
[GeometryType](#)

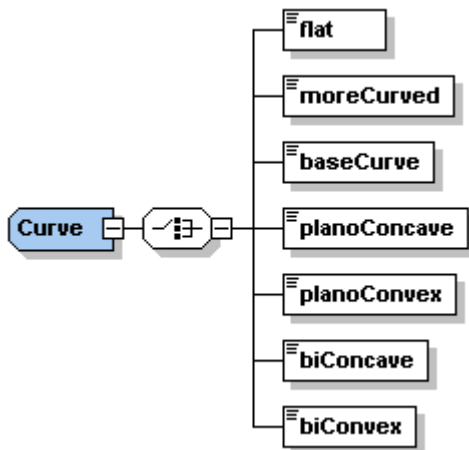

Elemente

flat

type: boolean
occurs: 1
description: nächste flachere Basiskurve verwenden

moreCurved

type: boolean
occurs: 1
description: nächste gebogenere Basiskurve verwenden
info: CZ: ignored

baseCurve

type: float
unity: dpt
occurs: 1
description: LngDE: Basiskurve
info: CZ: ignored

planoConcave

type: boolean
occurs: 1
description:
info: CZ: ignored

planoConvex

type: boolean
occurs: 1
description:
info: CZ: ignored

biConcave

type: boolean
occurs: 1
description:
info: CZ: ignored

biConvex

type: boolean
occurs: 1
description:
info: CZ: ignored

XSD

```
<xs:complexType name="Curve">
  <xs:choice>
    <xs:element name="flat" type="xs:boolean"/>
    <xs:element name="moreCurved" type="xs:boolean"/>
    <xs:element name="baseCurve" type="xs:float"/>
    <xs:element name="planoConcave" type="xs:boolean"/>
    <xs:element name="planoConvex" type="xs:boolean"/>
    <xs:element name="biConcave" type="xs:boolean"/>
    <xs:element name="biConvex" type="xs:boolean"/>
  </xs:choice>
</xs:complexType>
```

2.5.10 Cylinder

Used in

[RefractionSimple RXDataType RXDataType4SL](#)

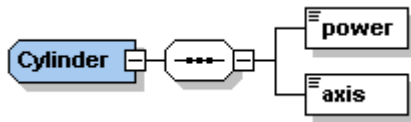

Elemente

power

type: float
unity: dpt
occurs: 1
description:

axis

type: float
unity: degree
minValue: 0.0
maxValue: 360.0
occurs: 1
description: Bis zur Version 1.2.3 war der Name des Feldes "base"

XSD

```
<xs:complexType name="Cylinder">
  <xs:sequence>
    <xs:element name="power" type="xs:float" />
    <xs:element name="axis">
      <xs:simpleType>
        <xs:restriction base="xs:float">
          <xs:minInclusive value="0.0" />
          <xs:maxInclusive value="360.0" />
        </xs:restriction>
      </xs:simpleType>
    </xs:element>
  </xs:sequence>
</xs:complexType>
```

2.5.11 Decentration

Used in
[GeometryType](#)

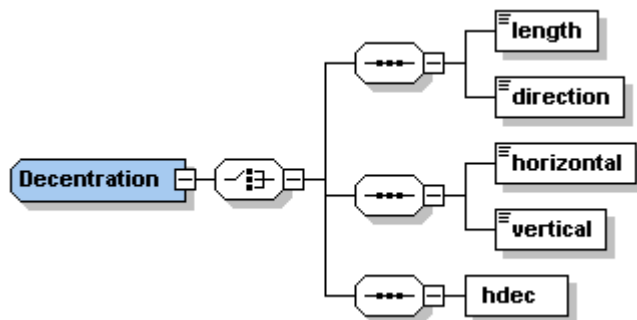

Elemente

length

type: float
unity: mm
min Value: 0.1
max Value: 40.0
occurs: 1
description: Länge des Verschiebevektors bei Polarkoordinaten

direction

type: integer
unity: degree
min Value: 0
max Value: 360
occurs: 1
description: Richtung der Verschiebung bei Polarkoordinaten

horizontal

type: float
unity: mm
occurs: 1
description: LngDe: horizontale Verschiebung bei kartesischen Koordinaten. positive Werte dezentrieren nach innen (Richtung nasal)
info: CZ, ROD: currently ignored - use length - direction instead!

vertical

type: float
unity: mm
occurs: 1
description: Lng:De vertikale Verschiebung bei kartesischen Koordinaten. positive Werte dezentrieren nach oben
info: CZ, ROD,SEI: currently ignored - use length - direction instead!

hdec

type: float

unity:	mm
occurs:	1
description:	LngDe: horizontaler Versatz des Durchblickpunktes oder anders ausgedrückt Erhöhung ausnutzbarer Durchmesser Dieses Feld mit dem Namen "horizontal decentration centring point" (HDEC) wird hauptsächlich bei Sport
und	freesign Gläsern angewandt zur Erhöhung des ausnutzbaren Durchmessers. Da es nur horizontal wirkt, ist keine Richtungsangabe notwendig, plus Werte dezentrieren nach innen (nasal).
info:	currently used only by ROD, SEI

XSD

```

<xs:complexType name="Decentration">
  <xs:choice>
    <xs:sequence>
      <xs:element name="length">
        <xs:simpleType>
          <xs:restriction base="xs:float">
            <xs:minInclusive value="0.1"/>
            <xs:maxInclusive value="40.0"/>
          </xs:restriction>
        </xs:simpleType>
      </xs:element>
      <xs:element name="direction">
        <xs:simpleType>
          <xs:restriction base="xs:integer">
            <xs:minInclusive value="0.0"/>
            <xs:maxInclusive value="360.0"/>
          </xs:restriction>
        </xs:simpleType>
      </xs:element>
    </xs:sequence>
    <xs:sequence>
      <xs:element name="horizontal" type="xs:float"/>
      <xs:element name="vertical" type="xs:float"/>
    </xs:sequence>
    <xs:sequence>
      <xs:element name="hdec" type="xs:float"/>
    </xs:sequence>
  </xs:choice>
</xs:complexType>

```

2.5.12 Diameter

Used in

[StockLens](#) [GeometryType](#)

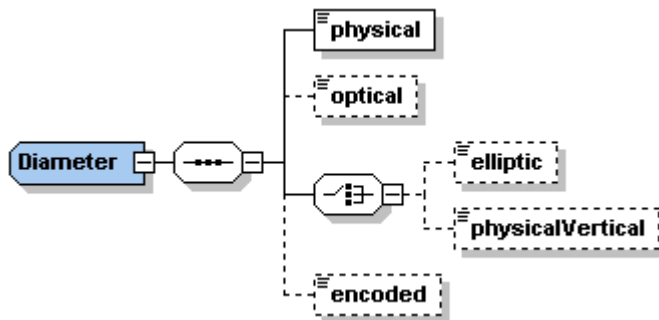

Elemente

physical

type: integer

unity: mm

min Value: 1

max Value: 99

occurs: 1

description:

info: Bei vordezentrierten Gläsern der physikalsche (kleinere) Durchmesser

optical

type: integer

unity: mm

min Value: 1

max Value: 99

occurs: 0..1

description:

info: Bei vordezentrierten Gläsern der optisch wirksame (größere) Durchmesser

elliptic

type: boolean

occurs: 0..1

description:

info:

physicalVertical

type: integer

unity: mm

min Value: 1

max Value: 99

occurs: 0..1

description:

info:

encoded

type: string
occurs: 0..1
description:
info:

XSD

```
<xs:complexType name="Diameter">
  <xs:sequence>
    <xs:element name="physical">
      <xs:simpleType>
        <xs:restriction base="xs:integer">
          <xs:minInclusive value="1"/>
          <xs:maxInclusive value="99"/>
        </xs:restriction>
      </xs:simpleType>
    </xs:element>
    <xs:element name="optical" minOccurs="0">
      <xs:simpleType>
        <xs:restriction base="xs:integer">
          <xs:minInclusive value="1"/>
          <xs:maxInclusive value="99"/>
        </xs:restriction>
      </xs:simpleType>
    </xs:element>
    <xs:element name="elliptic" type="xs:boolean" default="false" minOccurs="0"/>
    <xs:element name="encoded" type="xs:string" minOccurs="0"/>
  </xs:sequence>
</xs:complexType>
```

2.5.13 DrillHoles

Used in
[Frame](#)

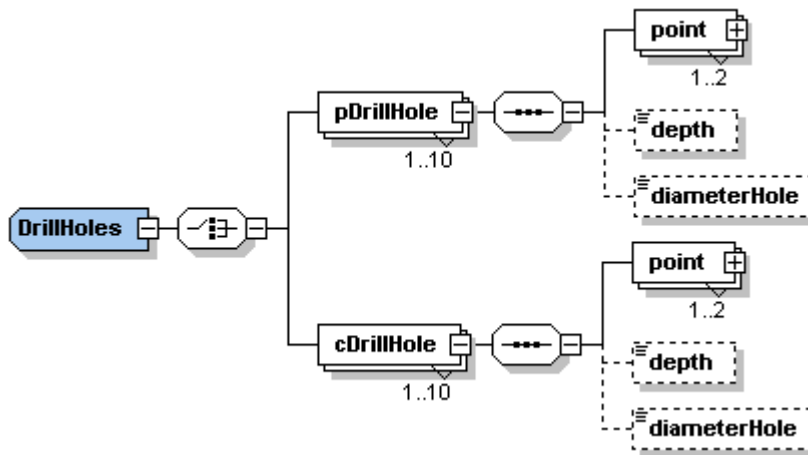

Elemente

pDrillHole

type: complex
occurs: 1..10
description:
info: CZ: ignored - use cDrillHole instead

Elemente für pDrillHole

point

type: [PPoint](#)
occurs: 1..2
description: Lng: Werden zwei Werte angegeben, dann diese als Endpunkte für ein Langloch interpretiert.

depth

type: float
unity: mm
occurs: 0..1
description:

diameterHole

type: float
unity: mm
occurs: 0..1
description:

cDrillHole

type: complex
occurs: 1..10
description:

Elemente für cDrillHole**point**

type: [CPoint](#)
occurs: 1..2
description: Lng: Werden zwei Werte angegeben, dann diese als Endpunkte für ein Langloch interpretiert.

depth

type: float
unity: mm
occurs: 0..1
description:

diameterHole

type: float
unity: mm
occurs: 0..1
description:

XSD

```
<xs:complexType name="DrillHoles">
  <xs:choice>
    <xs:element name="pDrillHole" maxOccurs="10">
      <xs:complexType>
        <xs:sequence>
          <xs:element name="point" type="PPoint" maxOccurs="2"/>
          <xs:element name="depth" type="xs:float" minOccurs="0"
            <xs:element name="diameterHole" type="xs:float"
minOccurs="0"/>
        </xs:sequence>
      </xs:complexType>
    </xs:element>
    <xs:element name="cDrillHole" maxOccurs="10">
      <xs:complexType>
        <xs:sequence>
          <xs:element name="point" type="CPoint" maxOccurs="2"
            <xs:element name="depth" type="xs:float" minOccurs="0"
            <xs:element name="diameterHole" type="xs:float"
minOccurs="0"/>
        </xs:sequence>
      </xs:complexType>
    </xs:element>
  </xs:choice>
</xs:complexType>
```

2.5.14 Edging

Used in

[Pair](#)

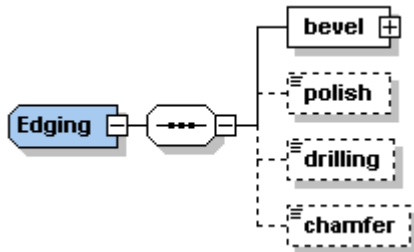

Attribute

edgingType

type: [EdgingType](#)

use: required

description:

info:

Elemente

bevel

type: [Bevel](#)

occurs: 1

description:

drilling

type: boolean

occurs: 0..1

description: in value=true then "/Frame/drillHoles" is used for drilling. Otherwise "/Frame/drillHoles" is just for information.

polish

type: boolean

occurs: 0..1

description:

chamfer

type: [CamferIntensity](#)

attribut: position (simpletype [ChamferPos](#))

occurs: 0..1

description:

info: CZ: ignored

XSD

2.5.15 Fitting

Used in

[Pair](#)



Elemente

place

type: [FittingPlace](#)

occurs: 1

description: LngDe: Infos zur Montage der Gläser in eine Fassung
Wird der Type "Fitting" verwendet, muss der Wert für [EdgingType](#) den Wert GIVENFRAME oder ORDEREDFRAME besitzen.

XSD

2.5.16 Frame

Used in

[Pair](#)

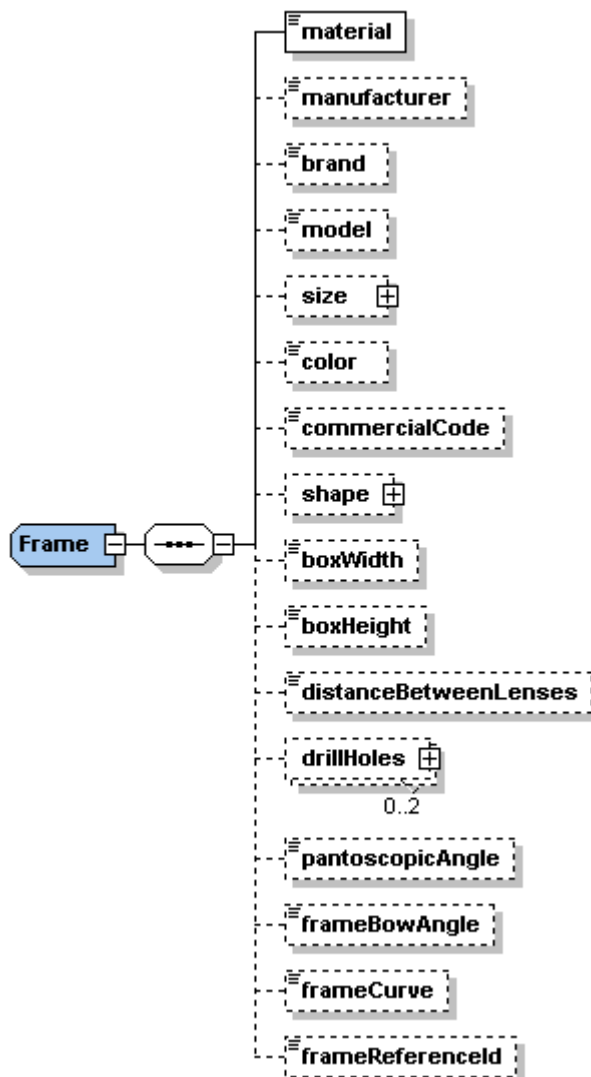

Attribute

quantity

type: integer
 use: required
 description:

Elemente

material

type: [FrameMaterials](#)

occurs: 1
description:
info: CZ: currently recognized: METAL, PLASTIC, NYLOR, SPECIAL

manufacturer

type: string
occurs: 0..1
description:

brand

type: string
occurs: 0..1
description:
info: CZ: ignored

model

type: string
occurs: 0..1
description:

size

type: [FrameSize](#)
occurs: 0..1
description: Nominal size information as given from frame manufacturer
info: CZ: currently ignored - use size elements under shape!

color

type: string
occurs: 0..1
description:
info: CZ: ignored

commercialCode

type: string
occurs: 0..1
description:
info: CZ: ignored

shape

type: complex
occurs: 0..1
description:

Elemente für shape

catalog

type:
occurs: 1..2
description: for thicknessreduction
Info: CZ: ignored

Elemente für catalog

shapeld

type: string
occurs: 1
description:

explicit

type: [Shape](#)
attribute: side ([SidesSimple](#))
occurs: 1..2
description:

traceData

type: [TracerData](#)
occurs: 1..2
description: necessary for remoteEdging/Presize

boxWidth

type: float
unity: mm
occurs: 0..1
description: measured box width for size transformations

boxHeight

type: float
unity: mm
occurs: 0..1
description: measured box height for size transformations

DistanceBetweenLenses

type: float
unity: mm
occurs: 0..1
description: measured dbl for calculation purposes

drillHoles

type: [DrillHoles](#)
attribute: side ([Sides](#))
occurs: 0..2
description:
info: CZ: If attribute side is UNDEFINED and drillHoles occurs only once the drillhole values are mirrored from right to left side

SEI: ignored

pantoscopicAngle

type: float
attribute: dimension ([AngleDimension](#))
occurs: 0..1
description: LngDE: Fassungsverneigung
info: ROD:possible value for AngleDimension: MM and DEG

frameBowAngle

type: float
attribute: dimension ([AngleDimension](#))

occurs: 0..1
description: LangDe: Fassungsscheibenwinkel
info:

frameCurve

type: float
unity: dpt
occurs: 0..1
description:
info: CZ: ignored

frameReferenceld

type: string
occurs: 0..1
description: todo:Beschreibung
info:

XSD

```

<xs:complexType name="Frame">
  <xs:sequence>
    <xs:element name="material" type="FrameMaterials" />
    <xs:element name="manufacturer" type="xs:string" minOccurs="0" />
    <xs:element name="brand" type="xs:string" minOccurs="0" />
    <xs:element name="model" type="xs:string" minOccurs="0" />
    <xs:element name="size" type="FrameSize" minOccurs="0" />
    <xs:element name="color" type="xs:string" minOccurs="0" />
    <xs:element name="commercialCode" type="xs:string" minOccurs="0" />
    <xs:element name="shape" minOccurs="0">
      <xs:complexType>
        <xs:sequence>
          <xs:choice>
            <xs:element name="catalog">
              <xs:complexType>
                <xs:sequence>
                  <xs:element name="
shapeld" type="xs:string" />
                </xs:sequence>
              </xs:complexType>
            </xs:element>
            <xs:element name="explicit" maxOccurs="2">
              <xs:complexType>
                <xs:complexContent>
                  <xs:extension base="
Shape">
                    <xs:attribute
name="side" type="SidesSimple" use="required" />
                  </xs:extension>
                </xs:complexContent>
              </xs:complexType>
            </xs:element>
            <xs:element name="tracerData" type="TracerData
"/>
          </xs:choice>
        </xs:sequence>
      </xs:complexType>
    </xs:element>
  </xs:sequence>
</xs:complexType>
  
```

```

</xs:element>
<xs:element name="boxWidth" type="xs:float" minOccurs="0" />
<xs:element name="boxHeight" type="xs:float" minOccurs="0" />
<xs:element name="distanceBetweenLenses" type="xs:float" minOccurs="0" />
<xs:element name="drillHoles" minOccurs="0" maxOccurs="2">
  <xs:complexType>
    <xs:complexContent>
      <xs:extension base="DrillHoles">
        <xs:attribute name="side" type="Sides" use="
required" />
      </xs:extension>
    </xs:complexContent>
  </xs:complexType>
</xs:element>
<xs:element name="pantoscopicAngle" minOccurs="0">
  <xs:complexType>
    <xs:simpleContent>
      <xs:extension base="xs:float">
        <xs:attribute name="dimension" type="
AngleDimension" use="optional" default="DEG" />
      </xs:extension>
    </xs:simpleContent>
  </xs:complexType>
</xs:element>
<xs:element name="frameBowAngle" minOccurs="0">
  <xs:complexType>
    <xs:simpleContent>
      <xs:extension base="xs:float">
        <xs:attribute name="dimension" type="
AngleDimension" use="optional" default="DEG" />
      </xs:extension>
    </xs:simpleContent>
  </xs:complexType>
</xs:element>
<xs:element name="frameCurve" type="xs:float" minOccurs="0" />
</xs:sequence>
<xs:attribute name="quantity" type="xs:integer" use="required" />
</xs:complexType>

```

2.5.17 FrameSize

Used in
[Frame](#)

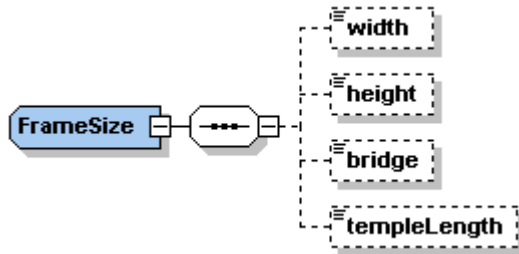

Elemente

width

type: float
unity: mm
occurs: 0..1
description:

height

type: float
unity: mm
occurs: 0..1
description:

bridge

type: float
unity: mm
occurs: 0..1
description:

templeLength

type: float
unity: mm
occurs: 0..1
description:

XSD

```
<xs:complexType name="FrameSize">
  <xs:sequence>
    <xs:element name="width" type="xs:float" minOccurs="0"/>
    <xs:element name="height" type="xs:float" minOccurs="0"/>
    <xs:element name="bridge" type="xs:float" minOccurs="0"/>
    <xs:element name="templeLength" type="xs:float" minOccurs="0"/>
  </xs:sequence>
</xs:complexType>
```

2.5.18 GeometryType

Used in

[Lens](#)

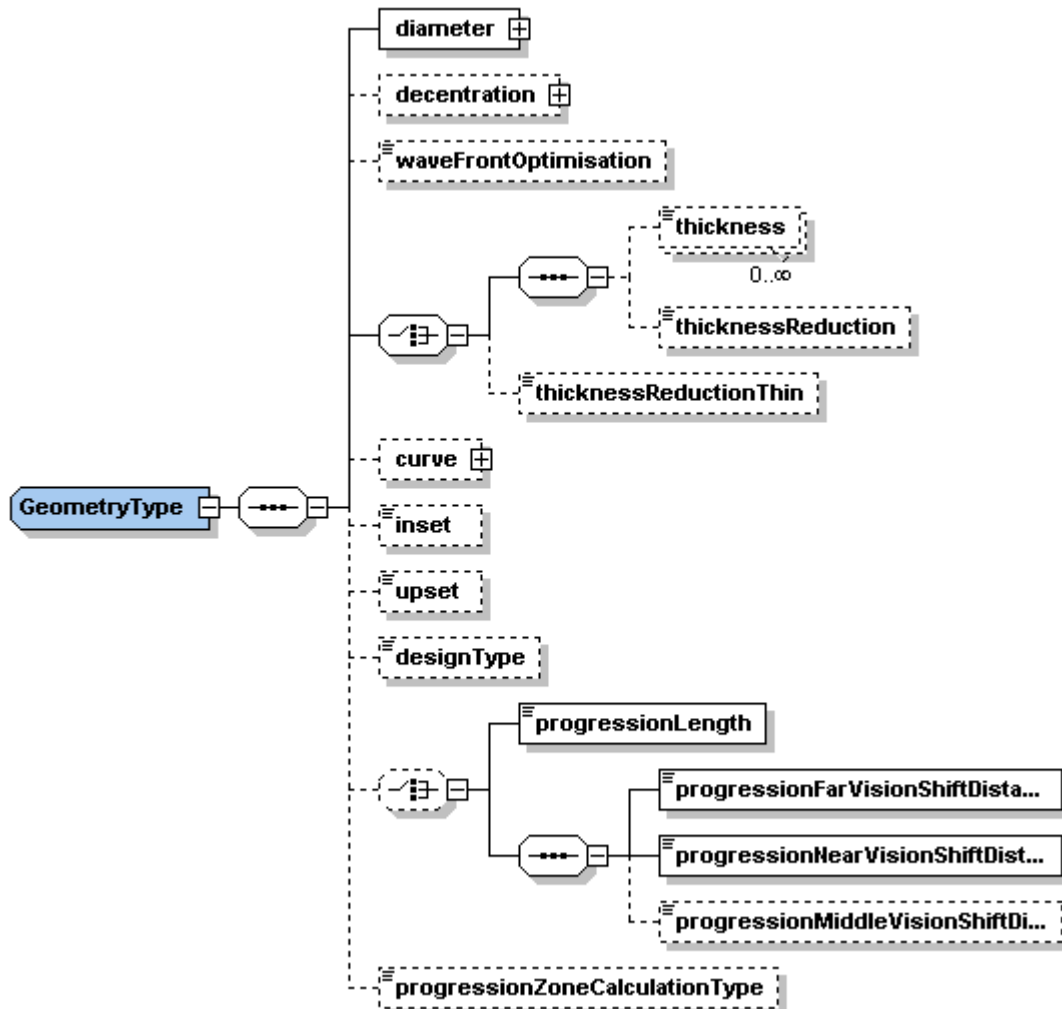

Elemente

diameter

type: [Diameter](#)
 occurs: 1
 description: DE:Bestelldurchmesser

decentration

type: [Decentration](#)
 occurs: 1
 description:

thickness

type: float
unity: mm
attribute: reference ([ThicknessReferences](#))
occurs: 0..1
description:
info:

thicknessReduction

type: boolean
occurs: 0..1
description: LngDe: TRUE = Anwahl der computerunterstützten Optimierung für die Rand- bzw. Mittendicke: Bei Zeiss entspricht dies der Anwahl OPTIMA
info: CZ: Flag for Optima
ROD: Flag for MDM.

thicknessReductionThin

type: boolean
occurs: 0..1
description: LngDe: Randscharf
info:

waveFrontOptimisation

type: boolean
occurs: 0..1
description: Kennzeichnet die kostenpflichtige Optimierung mit Hilfe der Wellenfrontdaten, die unter
info: patient:iProfilerData geschickt werden.
SEI: ignored

curve

type: [Curve](#)
occurs: 0..1
description: Durchbiegung des Glases

inset

type: float
unity: mm
occurs: 0..1
description: Horizontaler Versatz nasal vom Fernbezugspunkt zum Nahbezugspunkt bedingt durch die Akkomotation beim Nahsehen.
info: CZ: ignored

upset

type: float
unity: mm
occurs: 0..1
description: Vertikaler Abstand vom Fernbezugspunkt zum oberen Rand des Nahteil (nur bei Bifo- Trifo-Gläsern)
info: CZ: ignored
SEI: ignored

designType

type: string
occurs: 0..1
possibleValues:
A
B
C

description: Used by Seiko
info: CZ: ignored

progressionLength

type: float
unity: mm
occurs: 0..1
description: for progressive lenses with variable length of progressionzone
info: CZ: ignored

progressionFarVisionShiftDistance

type: float
unity: mm
occurs: 0..1
description: Far Vision Vertical Shift distance Bz to Bf
info: CZ: ignored
SEI: ignored

progressionNearVisionShiftDistance

type: float
unity: mm
occurs: 0..1
description: Near Vision Vertical Shift distance Bz to Bn
info: CZ: ignored
SEI: ignored

progressionNearVisionShiftDistance

type: float
unity: mm
occurs: 0..1
description: Near Vision Vertical Shift distance
info: CZ: ignored
SEI: ignored

progressionZoneCalculationType

type: string
occurs: 0..1
description: Type of calculation of the progression zone length
info: CZ: ignored
SEI: ignored

```

xs:complexType name="GeometryType">
  <xs:sequence>
    <xs:element name="diameter" type="Diameter"/>
    <xs:element name="decentration" type="Decentration"/>
    <xs:element name="thickness" minOccurs="0">
      <xs:complexType>
        <xs:simpleContent>
          <xs:extension base="xs:float">
            <xs:attribute name="reference" type="ThicknessReferences"
use="required"/>
          </xs:extension>
        </xs:simpleContent>
      </xs:complexType>
    </xs:element>
    <xs:element name="thicknessReduction" type="xs:boolean" minOccurs="0"/>
    <xs:element name="waveFrontOptimisation" type="xs:boolean" minOccurs="0"/>
    <xs:element name="curve" type="Curve" minOccurs="0"/>
    <xs:element name="inset" type="xs:float" minOccurs="0"/>
    <xs:element name="upset" type="xs:float" minOccurs="0"/>
    <xs:element name="designtype" minOccurs="0">
      <xs:simpleType>
        <xs:restriction base="xs:string">
          <xs:enumeration value="A"/>
          <xs:enumeration value="B"/>
          <xs:enumeration value="C"/>
        </xs:restriction>
      </xs:simpleType>
    </xs:element>
    <xs:choice minOccurs="0">
      <xs:element name="progressionLength" type="xs:float"/>
      <xs:sequence>
        <xs:element name="progressionFarVisionShiftDistance"/>
        <xs:element name="progressionNearVisionShiftDistance"/>
      </xs:sequence>
    </xs:choice>
    <xs:element name="progressionZoneCalculationType" type="xs:string" minOccurs="0"/>
  </xs:sequence>
</xs:complexType>

```

2.5.19 Header

Used in

[b2bOptic](#)

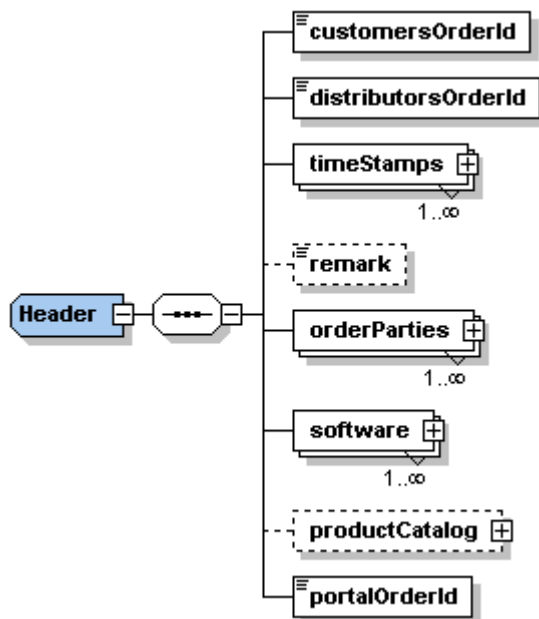

Attribute

msgType

type: [MsgTypes](#)
 use: optional
 default: REQUEST
 description:

msgState

type: [MsgStates](#)
 use: optional
 default: NEW
 description:

testIndicator

type: boolean
 use: optional
 default: 0
 description:

Elemente

customersOrderId

type: string
occurs: 1
description:
info: CZ: ignored

distributorsOrderId

type: string
occurs: 1
description:
info: CZ: ignored

timeStamps

type: [TimeStamps](#)
occurs: 1..n
description:
info: CZ: ignored

remark

type: string
occurs: 1
description:
info: CZ: Any comments or remarks are effectively ignored!

orderParties

type: [Account](#)
attribute: role (Type [Roles](#))
use: yes
occurs: 1..n
description: (LngDe) orderParties ist eine Ableitung von Account mit einem zusätzlichen Attribut role vom Type Roles.
info: CZ: at least one entry with @role ORIGINATOR or INVOICETO should be present, unless present under items/parties; serves as default - if nothing is specified in items branch, these entries are used

software

type: [Software](#)
occurs: 1..n
description:

productCatalog

type: [ProductCatalog](#)
occurs: 1
description:
info: SEI: ignored

portalOrderId

type: string
occurs: 1
description: retailer's order id
(LngDe)Bestellnummer des Optikers)
info: CZ: ignored

XSD

```

<xs:complexType name="Header">
  <xs:sequence>
    <xs:element name="customersOrderId" type="xs:string"/>
    <xs:element name="distributorsOrderId" type="xs:string"/>
    <xs:element name="timeStamps" type="TimeStamps" maxOccurs="unbounded"/>
    <xs:element name="remark" type="xs:string" minOccurs="0"/>
    <xs:element name="orderParties" maxOccurs="unbounded">
      <xs:complexType>
        <xs:complexContent>
          <xs:extension base="Account">
            <xs:attribute name="role" type="Roles" use="
required"/>
          </xs:extension>
        </xs:complexContent>
      </xs:complexType>
    </xs:element>
    <xs:element name="software" type="Software" maxOccurs="unbounded"/>
    <xs:element name="productCatalog" type="ProductCatalog" minOccurs="0"/>
    <xs:element name="portalOrderId" type="xs:string"/>
  </xs:sequence>
  <xs:attribute name="msgType" type="MsgTypes" use="optional" default="REQUEST"/>
  <xs:attribute name="msgState" type="MsgStates" use="optional" default="NEW"/>
  <xs:attribute name="testIndicator" type="xs:boolean" use="optional" default="0"/>
</xs:complexType>

```

2.5.20 IProfilerData

Used in

[Patient](#)

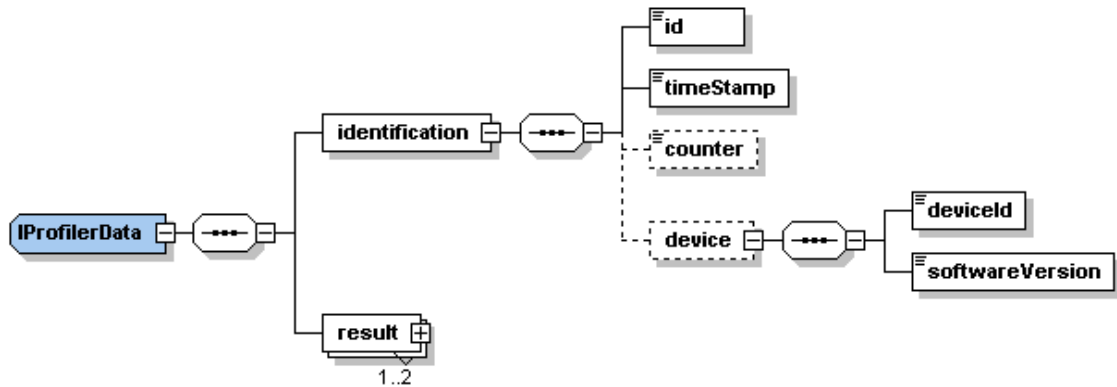

Elemente

identification

type:

occurs: 1

description:

Elemente für identification

id

type: string (1..50 Zeichen)

occurs: 1

description:

timeStamp

type: datetime

occurs: 1

description:

counter

type: int

minValue: 1

occurs: 0..1

description:

device

type:

occurs: 0..1

description:

Elemente für device

deviceId

type: String (1..50 Zeichen)
occurs: 1
description:

softwareVersion

type: String (1..50 Zeichen)
occurs: 1
description:

result

type: [iProfilerResult](#)
use: yes
occurs: 1
description:

XSD

```

<xs:complexType name="IProfilerData">
  <xs:sequence>
    <xs:element name="identification">
      <xs:complexType>
        <xs:sequence>
          <xs:element name="id">
            <xs:simpleType>
              <xs:restriction base="xs:string">
                <xs:minLength value="1"/>
                <xs:maxLength value="50"/>
              </xs:restriction>
            </xs:simpleType>
          </xs:element>
          <xs:element name="timeStamp" type="xs:dateTime"/>
          <xs:element name="counter" minOccurs="0">
            <xs:simpleType>
              <xs:restriction base="xs:int">
                <xs:minInclusive value="0"/>
              </xs:restriction>
            </xs:simpleType>
          </xs:element>
          <xs:element name="device" minOccurs="0">
            <xs:complexType>
              <xs:sequence>
                <xs:element name="deviceId">
                  <xs:simpleType>
                    <xs:restriction
base="xs:string">
                    <
                    <
                    <
                    </xs:restriction>
                  </xs:simpleType>
                </xs:element>
                <xs:element name="
softwareVersion">
                  <xs:simpleType>

```

```
base="xs:string">
xs:minLength value="1" />
xs:maxLength value="50" />
</xs:restriction>
</xs:simpleType>
</xs:element>
</xs:sequence>
</xs:complexType>
</xs:element>
</xs:sequence>
</xs:complexType>
</xs:element>
<xs:element name="result" type="IProfilerResult" maxOccurs="2" />
</xs:sequence>
</xs:complexType>
```

2.5.21 IProfilerMap

Used in

[IProfilerResult](#)

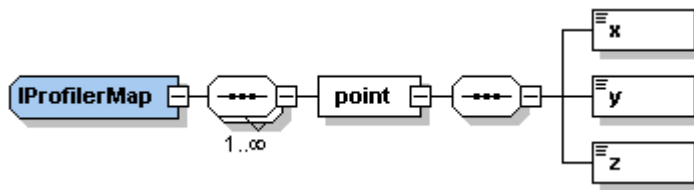

Elemente

point

type:

occurs: 1

description:

Elemente für point

X

type: float

unity: μm

occurs: 1

description:

Y

type: float

unity: μm

occurs: 1

description:

Z

type: float

unity: μm

occurs: 1

description:

XSD

```

<xs:complexType name="IProfilerMap">
  <xs:sequence maxOccurs="unbounded">
    <xs:element name="point">
      <xs:complexType>
        <xs:sequence>
          <xs:element name="x" type="xs:float" />
          <xs:element name="y" type="xs:float" />
          <xs:element name="z" type="xs:float" />
        </xs:sequence>
      </xs:complexType>
    </xs:element>
  </xs:sequence>
</xs:complexType>
  
```

```
        </xs:element>  
    </xs:sequence>  
</xs:complexType>
```

2.5.22 IProfilerResult

Used in
[IProfilerData](#)

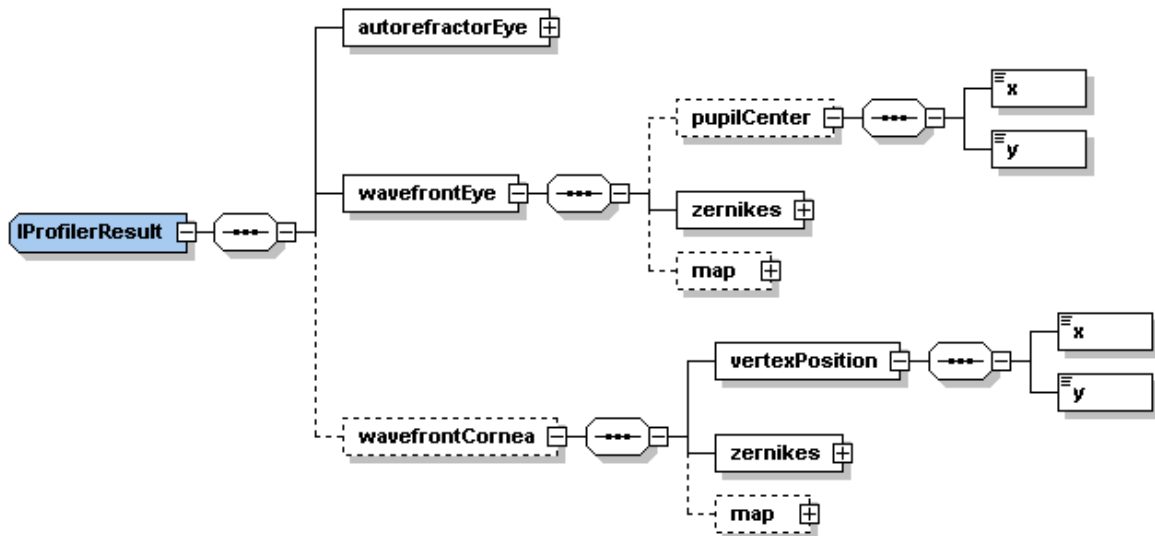

Attribute

side

type: [Sides](#)

use: yes

description:

Elemente

autorefractorEye

type: [RXDataTypeSimple](#)

occurs: 1

description:

wavefrontEye

type:

occurs: 1

description:

Elemente für wavefrontEye

pupilCenter

type:

occurs: 1

description:

Elemente für pupilCenter

X
type: float
unity: mm
occurs: 1
description:

Y
type: float
unity: mm
occurs: 1
description:

zernikes

type: Zernikes
occurs: 1
description:

map

type: [IProfilerMap](#)
occurs: 0..1
description:

wavefrontCornea

type:
occurs: 0..1
description:

Elemente für wavefrontCornea**vertexPosition**

type:
occurs: 1
description:

Elemente für vertexPosition

X
type: float
unity: mm
occurs: 1
description:

Y
type: float
unity: mm
occurs: 1
description:

zernikes

type: Zernikes
occurs: 1
description:

map
type: [IProfilerMap](#)
occurs: 1
description:

XSD

```

<xs:complexType name="IProfilerResult" >
  <xs:sequence>
    <xs:element name="autorefractorEye" type="RefractionSimple" />
    <xs:element name="wavefrontEye" >
      <xs:complexType>
        <xs:sequence>
          <xs:element name="pupilCenter" minOccurs="0" >
            <xs:complexType>
              <xs:sequence>
                <xs:element name="x" type="
xs:float" />
                <xs:element name="y" type="
xs:float" />
              </xs:sequence>
            </xs:complexType>
          </xs:element>
          <xs:element name="zernikes" type="Zernikes" />
          <xs:element name="map" type="IProfilerMap" minOccurs="
0" />
        </xs:sequence>
      </xs:complexType>
    </xs:element>
    <xs:element name="wavefrontCornea" minOccurs="0" >
      <xs:complexType>
        <xs:sequence>
          <xs:element name="vertexPosition" >
            <xs:complexType>
              <xs:sequence>
                <xs:element name="x" type="
xs:float" />
                <xs:element name="y" type="
xs:float" />
              </xs:sequence>
            </xs:complexType>
          </xs:element>
          <xs:element name="zernikes" type="Zernikes" />
          <xs:element name="map" type="IProfilerMap" minOccurs="
0" />
        </xs:sequence>
      </xs:complexType>
    </xs:element>
    <xs:attribute name="side" type="Sides" use="required" />
  </xs:sequence>
</xs:complexType>

```

2.5.23 Item

Used in

[b2bOptic](#)

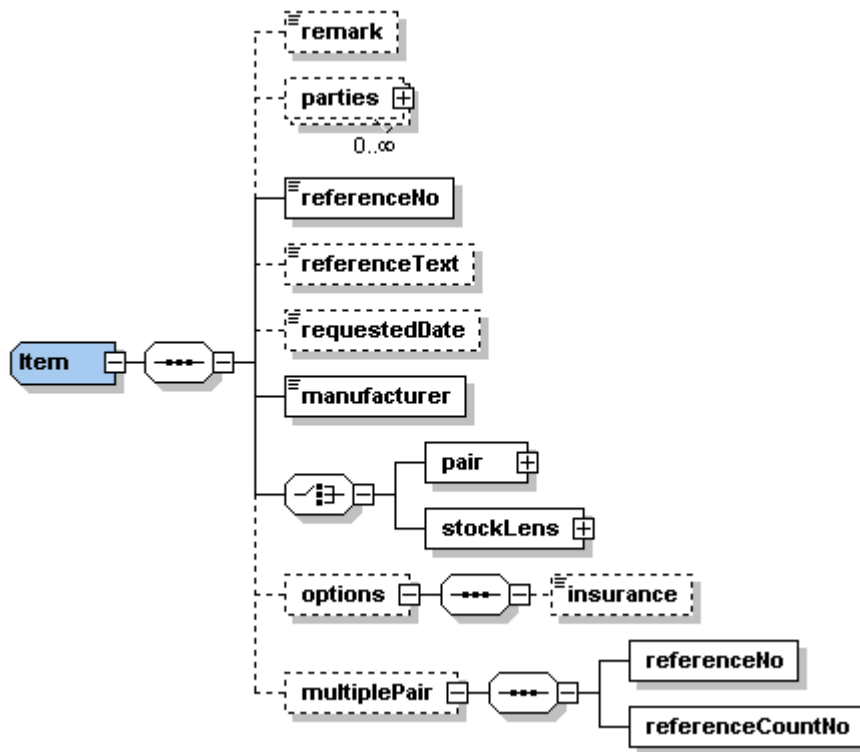

Elemente

remark

type: string

occurs: 0..1

description:

info: CZ: Any comments or remarks are effectively ignored!

parties

type: [Account](#)

attribute: role (Type [Roles](#))

occurs: 0..n

description: LngDe: orderParties ist eine Ableitung von Account mit einem zusätzlichen Attribut role vom Type Roles

if not given use defaults from header. "

Verwendung siehe orderparties ([Header](#))"

info:

referenceNo

type: string

occurs: 1

description: buyer's job no.

referenceText

type: string

occurs: 0..1

description: buyer's commission

info: CZ: currently ignored - use referenceNo also for textual references (commission)

requestedDate

type: date

occurs: 0..1

description:

info: CZ,SEI: currently ignored

manufacturer

type: string

occurs: 1

description:

info: CZ, SEI: currently ignored

pair

type: [Pair](#)

occurs: 1

description:

stockLens

type: [StockLens](#)

occurs: 1

description:

info: CZ: currently ignored

options

type:

occurs: 0..1

description:

Weitere Elemente für options

insurance

type: boolean

occurs: 0..1

description: LngDe: Inkl. Versicherung

info: CZ,SEI: Ignored

ROD: Nur Versicherungsvertragskunden können mit insurance=false für

einzelne Gläser die

möglich) Versicherung ausschalten (In deutsch, da derzeit nur mit deutschen Kunden

multiplePair

type:

occurs: 0..1
description:
info: CZ, Rod :ignored
 Currently only used by ESS.

Weitere Elemente für multiplePair

referenceNo

type: string
occurs: 1
description: LngDe: Referenz-Nr des Basisauftrag
info: CZ: Ignored
 ROD: Ignored

referenceCountNo

type: integer
occurs: 1
description: LngDe: Laufende Nummer
info: CZ: Ignored
 ROD: Ignored

XSD

```

<xs:complexType name="Item">
  <xs:sequence>
    <xs:element name="remark" type="xs:string" minOccurs="0"/>
    <xs:element name="parties" minOccurs="0" maxOccurs="unbounded">
      <xs:complexType>
        <xs:complexContent>
          <xs:extension base="Account">
            <xs:attribute name="role" type="Roles" use="
required"/>
          </xs:extension>
        </xs:complexContent>
      </xs:complexType>
    </xs:element>
    <xs:element name="referenceNo" type="xs:string"/>
    <xs:element name="referenceText" type="xs:string" minOccurs="0"/>
    <xs:element name="requestedDate" type="xs:date" minOccurs="0"/>
    <xs:element name="manufacturer" type="xs:string"/>
    <xs:choice>
      <xs:element name="pair" type="Pair"/>
      <xs:element name="stockLens" type="StockLens"/>
    </xs:choice>
    <xs:element name="options" minOccurs="0">
      <xs:complexType>
        <xs:sequence>
          <xs:element name="insurance" type="xs:boolean"
minOccurs="0"/>
        </xs:sequence>
      </xs:complexType>
    </xs:element>
  </xs:sequence>
</xs:complexType>
  
```

</xs:complexType>

2.5.24 Lens

Used in
[Pair](#)

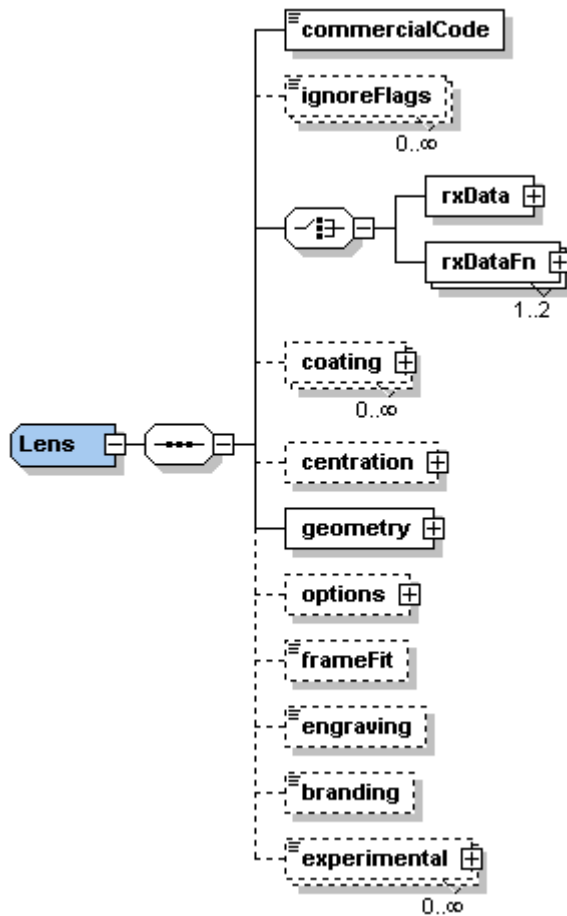

Attribute

side

type: [Sides](#)

use: required

description: Kennzeichnet das Glas als rechtes oder linkes Glas. UNDEFINED ist nur bei Einstärkengläsern erlaubt, die sowohl als rechtes und linkes Glas verwendet werden können.

balancingLens

type: boolean

use: optional

Default: 0

description: LngDe: CZ: Bei Zeiss nur bedingt sinnvoll nutzbar, da auch als Ausgleichsglas ein vollwertiges Glas bestellt werden muss.

virtualLens

type: boolean
use: optional
Default: 0
description: LngDe: TRUE definiert das Glas als virtuell. Dies kann verwendet werden um ein „virtuelles Glas“ für die Berechnung eines Glaspaares mit übergeben zu können.
info: CZ: ignored

Elemente**commercialCode**

type: string
occurs: 1
description:

ignoreFlags

type: string
occurs: 0..n
description:
info: CZ, SEI: ignored
 ROD:LngDe: ist einer der folgenden Statusnr. eingetragen, wird entsprechender Fehler ignoriert

107	Kommissions-Nr. doppelt
225	Prisma R/L > 3 dpt unterschiedlich
304	Brückenweite < 5mm oder > 40mm
362	Nahtteilrand außerhalb der Form
523	Fassungsvorneigung < -10° oder > +20°
524	Fassungsscheibenwinkel < -10° oder > +35°

rxData

type: [RXDataType](#)
occurs: 1
description:

rxDataFn

type: [RXDataTypeFarNear](#)
occurs: 1..2
description:

coating

type: [Coating](#)
occurs: 0..n
description:

centration

type: [Centration](#)
occurs: 0..1
description:

geometry

type: [GeometryType](#)
occurs: 1

description:

options

type:

occurs: 0..1

description:

Elemente für options

occlusion

type: boolean

occurs: 0..1

description:

frosted

type: boolean

occurs: 0..1

description: (german: Mattieren)

slaboff

type: boolean

occurs: 0..1

description:

framefit

type: float

unity:

occurs: 0..1

description: Progressionslänge für Zeiss-FrameFit-Gläser mit Wertebereich von 0 bis 6. 4 ist der Standardwert.

info: CZ: Size correction for the length of progression zone.
ROD: ignored

engraving

type: string

occurs: 0..1

description: String mit Zeichen, die in die Brille eingraviert werden

info: CZ: Individual gravure text, max five characters. Note: Not all characters supported!

experimental

type: anyType

occurs: 0..n

description:

branding

type: boolean

occurs: 0..1

description: Logo des Herstellers gravieren

info: Currently used only by Essilor and Rodenstock

XSD

```

<xs:complexType name="Lens">
  <xs:sequence>
    <xs:element name="commercialCode" type="xs:string" />
    <xs:element name="ignoreFlags" type="xs:string" minOccurs="0" maxOccurs="
unbounded" />
    <xs:element name="rxData">
      <xs:complexType>
        <xs:complexContent>
          <xs:extension base="RXDataType" />
        </xs:complexContent>
      </xs:complexType>
    </xs:element>
    <xs:element name="coating" type="Coating" minOccurs="0" maxOccurs="unbounded
"/>
    <xs:element name="centration" type="Centration" minOccurs="0" />
    <xs:element name="geometry" type="GeometryType" />
    <xs:element name="options" minOccurs="0">
      <xs:complexType>
        <xs:sequence>
          <xs:choice minOccurs="0">
            <xs:element name="occlusion" type="xs:boolean" />
            <xs:element name="frosted" type="xs:boolean" />
          </xs:choice>
          <xs:element name="slabOff" minOccurs="0">
            <xs:complexType>
              <xs:simpleContent>
                <xs:extension base="xs:boolean" />
              </xs:simpleContent>
            </xs:complexType>
          </xs:element>
        </xs:sequence>
      </xs:complexType>
    </xs:element>
    <xs:element name="frameFit" type="xs:float" minOccurs="0" />
    <xs:element name="engraving" minOccurs="0">
      <xs:simpleType>
        <xs:restriction base="xs:string" />
      </xs:simpleType>
    </xs:element>
    <xs:element name="experimental" type="xs:anyType" minOccurs="0" maxOccurs="
unbounded" />
  </xs:sequence>
  <xs:attribute name="side" type="Sides" use="required" />
  <xs:attribute name="balancingLens" type="xs:boolean" use="optional" default="0" />
  <xs:attribute name="virtualLens" type="xs:boolean" use="optional" default="0" />
</xs:complexType>

```

2.5.25 Pair

Used in
[Item](#)

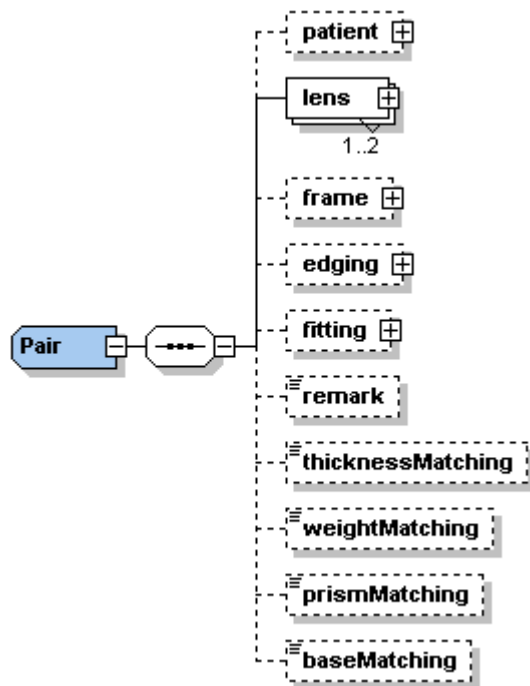

Elemente

patient

type: [Patient](#)
occurs: 1
description:

lens

type: [Lens](#)
attribute: quantity (Type integer)
occurs: 1..2
description: LngDe: lens ist eine Ableitung von Lens mit einem zusätzlichen Attribut quantity vom Type integer
info: CZ: any quantity other than 1 will result in an exception thrown to the client! YOU HAVE BEEN WARNED!

frame

type: [Frame](#)
occurs: 0..1
description:

edging

type: [Edging](#)
occurs: 0..1

description:

fitting

type: [Fitting](#)

occurs: 0..1

description:

remark

type: string

occurs: 1

description:

info: CZ: Any comments or remarks are effectively ignored!

thicknessMatching

type: boolean

use: optional

description: thickness balance

LngDe: Dickenangleichung

info: CZ: Bei Zeiss gibt es nur das Flag für „Angleichen“, der Kunde kann nicht wählen was

genau er angeglichen haben will. Da es kein allgemeines Flag für „Matching“ gibt

nutzt

Zeiss thicknessMatching für das allgemeine „Angleichen“. Je nach Bedarf gleicht

Zeiss die

Basiskurve und / oder die Dicke an, so das die Gläser möglichst gleich aussehen.

SEI:ignored

weightMatching

type: boolean

use: optional

description: weight balance

LngDe: Gewichtsangleichung

info: CZ, SEI: ignored

prismMatching

type: boolean

use: optional

description: prism balance LngDe:Prismenverteilung auf beide Gläser

info: CZ, SEI: ignored :

baseMatching

type: boolean

use: optional

description: LngDe:Basiskurvenangleichung

info: CZ, ROD: ignored:

XSD

2.5.26 Patient

Used in

[Pair](#)



Remark: /Patient/name should not be used. Instead of, please use /Patient/contact/Lastname

mailAllowed

type: boolean
occurs: 0..1
description:
info: CZ: ignored

gender

type: [Gender](#)
occurs: 0..1
description:
info: CZ: ignored

dateOfBirth

type: dateTime
occurs: 0..1
description:
info: CZ: ignored

interpupillaryDistanceRight

type: float
unity: mm
occurs: 0..1
description: Right PD of Patient. Do not use for centration.
For centration use Element [Centration](#)
info: CZ,SEI: ignored

interpupillaryDistanceLeft

type: float
unity: mm
occurs: 0..1
description: Left PD Patient. Do not use for centration.
For centration use Element [Centration](#)
info: CZ,SEI: ignored

nearObjectDistance

type: float
unity: mm
occurs: 0..1
description:

middleObjectDistance

type: float
unity: mm
occurs: 0..1
description:

farObjectDistance

type: float
unity: mm
occurs: 0..1
description:

nearRefractionDistance

type: float
unity: cm
occurs: 0..1
description:

additionRefractionMethod

type: [AdditionRefractionMethod](#)
occurs: 0..1
description:

backVertexDistanceRefraction

type: float
unity: mm
occurs: 0..1
description:

iProfilerData

type: [IProfilerData](#)
occurs: 0..1
description:
info: ROD:ignored
SEI: ignored

headTilt

type: float
unity: cm
occurs: 0..1
description:

ipseo

type: complexType
occurs: 0..1
description: Element for Essilor-Ipseo-Lenses
info: ROD,CZ :ignored

Elemente für ipseo

he

type: float
occurs: 0..1
description: value for Head-Eye-coefficient

st

type: float
occurs: 0..1
description: value for Stab-coefficient

headCape

type: float
unity: degree
occurs: 0..1
description: Element for Essilor - Visioffice

applianceWeighttype: [ApplianceWeight](#)

occurs: 0..1

description:

XSD

```

<xs:complexType name="Patient">
  <xs:complexContent>
    <xs:extension base="Account">
      <xs:sequence minOccurs="0">
        <xs:element name="mailAllowed" type="xs:boolean"
default="false" minOccurs="0"/>
        <xs:element name="gender" type="Gender"
minOccurs="0"/>
        <xs:element name="dateOfBirth" type="xs:date"
minOccurs="0"/>
        <xs:sequence minOccurs="0">
          <xs:element name="
interpupillaryDistanceRight" type="xs:float"/>
          <xs:element name="
interpupillaryDistanceLeft" type="xs:float"/>
        </xs:sequence>
        <xs:element name="nearObjectDistance" type="
xs:float" minOccurs="0"/>
        <xs:element name="nearRefractionDistance" type="
xs:float" minOccurs="0"/>
        <xs:element name="additionRefractionMethod" type="
"AdditionRefractionMethod" minOccurs="0"/>
        <xs:element name="iProfilerData" type="
IProfilerData" minOccurs="0"/>
        <xs:element name="headTilt" type="xs:float"
minOccurs="0"/>
        <xs:element name="ipseo" minOccurs="0">
          <xs:complexType>
            <xs:sequence>
              <xs:element name="he" type="
xs:float"/>
              <xs:element name="st" type="
xs:float"/>
            </xs:sequence>
          </xs:complexType>
        </xs:element>
      </xs:sequence>
    </xs:extension>
  </xs:complexContent>
</xs:complexType>

```

2.5.27 PPoint

Used in

[Shape](#)

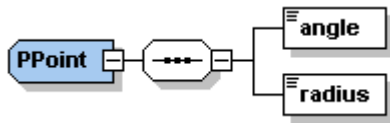

Elemente

angle

type: float
unity: see dimension
attribute: dimension ([AngleDimension](#))
occurs: 1
description:
info: ROD:possible value for AngleDimension: DEG

radius

type: float
unity: mm
occurs: 1
description:

XSD

```

<xs:complexType name="PPoint">
  <xs:sequence>
    <xs:element name="angle">
      <xs:complexType>
        <xs:simpleContent>
          <xs:extension base="xs:float">
            AngleDimension" use="optional" default="DEG"/>
          </xs:extension>
        </xs:simpleContent>
      </xs:complexType>
    </xs:element>
    <xs:element name="radius" type="xs:float"/>
  </xs:sequence>
</xs:complexType>
  
```

2.5.28 Prism

Used in

[RXDataType](#)

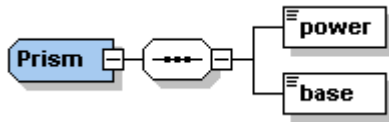

Elemente

power

type: float
unity: cm/m
occurs: 1
description:

base

type: float
unity: degree
minValue: 0.0
maxValue: 360.0
occurs: 1
description:

XSD

```
<xs:complexType name="Prism">
  <xs:sequence>
    <xs:element name="power" type="xs:float" />
    <xs:element name="base">
      <xs:simpleType>
        <xs:restriction base="xs:float">
          <xs:minInclusive value="0.0" />
          <xs:maxInclusive value="360.0" />
        </xs:restriction>
      </xs:simpleType>
    </xs:element>
  </xs:sequence>
</xs:complexType>
```

2.5.29 ProductCatalog

Used in

[Header](#)

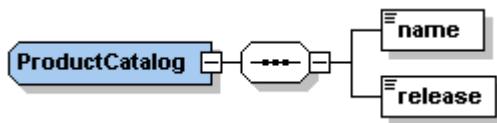

Elemente

name

type: string

possible values: czv
sf4
sf6
optimeyes
euronet

occurs: 1

description:

info: CZ: ignored

release

type: string

occurs: 1

description: Für SF6 sollte hier die UID-Manufacturer aus der Datei Head.Dat stehen

info: CZ: ignored

XSD

```

<xs:complexType name="ProductCatalog">
  <xs:sequence>
    <xs:element name="name">
      <xs:simpleType>
        <xs:restriction base="xs:string">
          <xs:enumeration value="czv"/>
          <xs:enumeration value="sf4"/>
          <xs:enumeration value="sf6"/>
          <xs:enumeration value="optimeyes"/>
          <xs:enumeration value="euronet"/>
        </xs:restriction>
      </xs:simpleType>
    </xs:element>
    <xs:element name="release" type="xs:string"/>
  </xs:sequence>
</xs:complexType>
  
```

2.5.30 RXDataTypeSimple

Used in

[IProfilerResult](#)

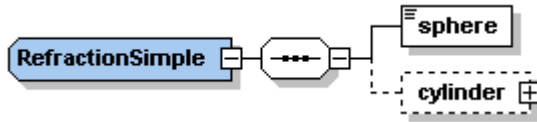

Elemente

sphere

type: float
unity: dpt
minValue: -50
maxValue: 50
occurs: 1
description:

cylinder

type: [Cylinder](#)
occurs: 0..1
description:

XSD

```

<xs:complexType name="RXDataTypeSimple">
  <xs:sequence>
    <xs:element name="sphere">
      <xs:simpleType>
        <xs:restriction base="xs:float">
          <xs:minInclusive value="-50"/>
          <xs:maxInclusive value="50"/>
        </xs:restriction>
      </xs:simpleType>
    </xs:element>
    <xs:element name="cylinder" type="Cylinder" minOccurs="0"/>
  </xs:sequence>
</xs:complexType>

```

2.5.31 RXDataType

Used in

[Lens](#)

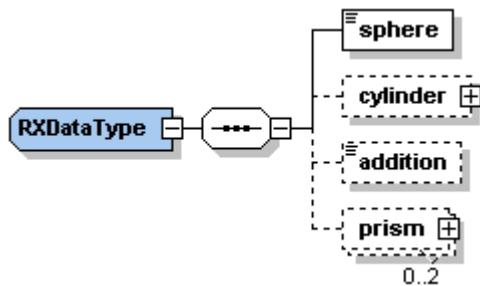

Elemente

sphere

type: float
unity: dpt
occurs: 1
description:

cylinder

type: [Cylinder](#)
occurs: 0..1
description:

addition

type: float
unity: dpt
minValue: 0.25
occurs: 0..1
description:

prism

type: [Prism](#)
occurs: 0..2
description:

XSD

```

<xs:complexType name="RXDataType">
  <xs:sequence>
    <xs:element name="sphere">
      <xs:simpleType>
        <xs:restriction base="xs:float">
          <xs:minInclusive value="-50"/>
          <xs:maxInclusive value="50"/>
        </xs:restriction>
      </xs:simpleType>
    </xs:element>
    <xs:element name="cylinder" type="Cylinder" minOccurs="0"/>
  
```

```
<xs:element name="addition" minOccurs="0">
  <xs:simpleType>
    <xs:restriction base="xs:float">
      <xs:minInclusive value="0.25" />
    </xs:restriction>
  </xs:simpleType>
</xs:element>
<xs:element name="prism" type="Prism" minOccurs="0" maxOccurs="2" />
</xs:sequence>
</xs:complexType>
```

2.5.32 RxDataTypeFarNear

Used in

[Lens](#)

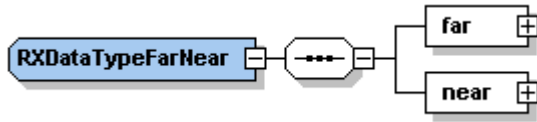

Attribute

reference

type: [RxDataReferences](#)

use: required

description:

Elemente

far

type: [RxDataTypeFn](#)

occurs: 1

description:

near

type: [RxDataTypeFn](#)

occurs: 1

description:

XSD

2.5.33 RxDataTypeFn

Used in

[RxDataTypeFarNear](#)

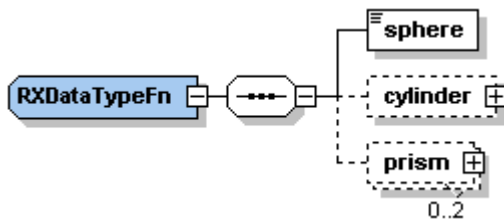

Elemente

sphere

type: float
unity: dpt
occurs: 1
description:

cylinder

type: [Cylinder](#)
occurs: 0..1
description:

prism

type: [Prism](#)
occurs: 0..2
description:

XSD

```

<xs:complexType name="RXDataType">
  <xs:sequence>
    <xs:element name="sphere">
      <xs:simpleType>
        <xs:restriction base="xs:float">
          <xs:minInclusive value="-50"/>
          <xs:maxInclusive value="50"/>
        </xs:restriction>
      </xs:simpleType>
    </xs:element>
    <xs:element name="cylinder" type="Cylinder" minOccurs="0"/>
    <xs:element name="prism" type="Prism" minOccurs="0" maxOccurs="2"/>
  </xs:sequence>
</xs:complexType>
  
```

2.5.34 RXDataType4SL

Used in

[StockLens](#)

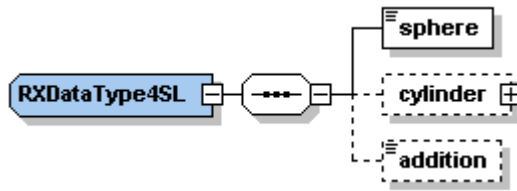

Elemente

sphere

type: float
unity: dpt
minValue: -50
maxValue: 50
occurs: 1
description:

cylinder

type: [Cylinder](#)
occurs: 0..1
description:

addition

type: float
unity: dpt
minValue: 0.25
occurs: 0..1
description:

XSD

```

<xs:complexType name="RXDataType4SL">
  <xs:sequence>
    <xs:element name="sphere">
      <xs:simpleType>
        <xs:restriction base="xs:float">
          <xs:minInclusive value="-50"/>
          <xs:maxInclusive value="50"/>
        </xs:restriction>
      </xs:simpleType>
    </xs:element>
    <xs:element name="cylinder" type="Cylinder" minOccurs="0"/>
    <xs:element name="addition" minOccurs="0">
      <xs:simpleType>
        <xs:restriction base="xs:float">
          <xs:minInclusive value="0.25"/>
        </xs:restriction>
      </xs:simpleType>
    </xs:element>
  </xs:sequence>
</xs:complexType>
  
```

```
</xs:simpleType>  
</xs:element>  
</xs:sequence>  
</xs:complexType>
```

2.5.35 Shape

Used in
[Frame](#)

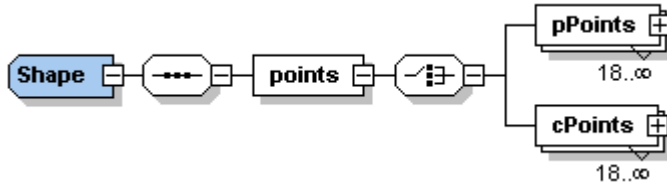

Elemente

points

type:

occurs: 1

description: LngDe: Formdaten werden "Boxzentriert" angegeben.

Elemente für points

pPoints

type: [PPoint](#)

occurs: 18..n

description:

info:

CZ: In an order (header[@msgType=ORDER]) any number of polar coordinates other than 36 will result in an exception thrown to the client.

cPoints

type: [cPoint](#)

occurs: 18..n

description:

info:

CZ: currently ignored - use polar coordinates instead!

XSD

```

<xs:complexType name="Shape">
  <xs:sequence>
    <xs:element name="points">
      <xs:complexType>
        <xs:choice>
          <xs:element name="pPoints" type="PPoint" minOccurs="18"
            " maxOccurs="unbounded" />
          <xs:element name="cPoints" type="CPoint" minOccurs="18"
            " maxOccurs="unbounded" />
        </xs:choice>
      </xs:complexType>
    </xs:element>
  </xs:sequence>
</xs:complexType>
  
```

2.5.36 Software

Used in

[Header](#)

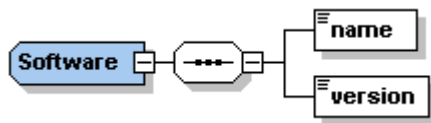

Attribute

typeOf

type: [SoftwareTypes](#)

use: required

description:

Elemente

name

type: string

occurs: 1

description:

version

type: string

occurs: 1

description:

XSD

```
<xs:complexType name="Software">
  <xs:sequence>
    <xs:element name="name" type="xs:string"/>
    <xs:element name="version" type="xs:string"/>
  </xs:sequence>
  <xs:attribute name="typeOf" type="SoftwareTypes" use="required"/>
</xs:complexType>
```

2.5.37 StockLens

Used in

[Pair Item](#)

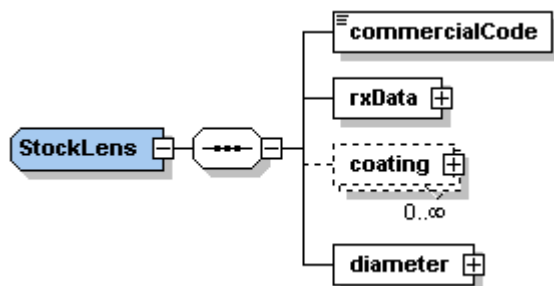

Attribute

quantity

type: integer
use: required
description:

side

type: [Sides](#)
use: required
description:

Elemente

commercialCode

type: string
occurs: 1
description:

rxData

type: [RXDataType4SL](#)
occurs: 1
description:

coating

type: [Coating](#)
occurs: 0..n
description:

diameter

type: Diameter
occurs: 1
description:

XSD

```
<xs:complexType name="StockLens">
  <xs:sequence>
    <xs:element name="commercialCode" type="xs:string"/>
    <xs:element name="rxData" type="RXDataType4SL"/>
    <xs:element name="coating" type="Coating" minOccurs="0" maxOccurs="unbounded" />
  </xs:sequence>
  <xs:element name="diameter" type="Diameter" />
  <xs:attribute name="quantity" type="xs:integer" use="required" />
  <xs:attribute name="side" type="Sides" use="required" />
</xs:complexType>
```

2.5.38 TimeStamps

Used in

[Header](#)



Elemente

dateTime

type: dateTime
attribute: step (Type [MsgSteps](#))
occurs: 1
description:

XSD

```

<xs:complexType name="TimeStamps">
  <xs:sequence>
    <xs:element name="dateTime">
      <xs:complexType>
        <xs:simpleContent>
          <xs:extension base="xs:dateTime">
            <xs:attribute name="step" type="MsgSteps" use="
required" />
          </xs:extension>
        </xs:simpleContent>
      </xs:complexType>
    </xs:element>
  </xs:sequence>
</xs:complexType>
  
```

2.5.39 TracerData

Used in
[Frame](#)

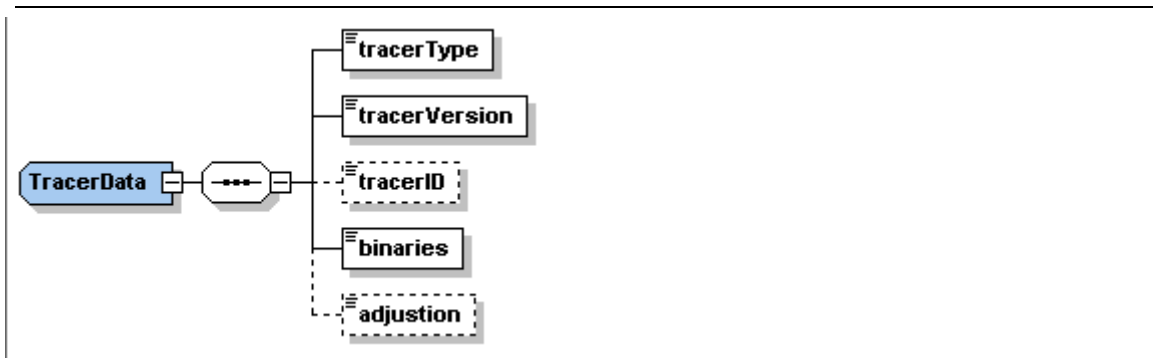

Elemente

tracerType

type: [TracerType](#)
 occurs: 1
 description:

tracerVersion

type: string
 occurs: 1
 description:
 info: CZ: ignored

TracerId

type: string
 occurs: 0..1
 description: Serialnumber of tracer

binaries

type: hexBinary
 attribute: format (Type [TracerBinaryFormat](#))
 occurs: 1
 description:

adjustion

type: float
 unity: mm
 occurs: 0..1
 description: general size adjustment parameter
 info: CZ: Size correction in the Nidek data set.
 ROD: ignored

XSD

```
<xs:complexType name="TracerData" >
  <xs:sequence>
    <xs:element name="tracerType" type="TracerType" />
    <xs:element name="tracerVersion" type="xs:string" />
    <xs:element name="tracerID" type="xs:string" minOccurs="0" />
    <xs:element name="binaries" >
      <xs:complexType>
        <xs:simpleContent>
          <xs:extension base="xs:hexBinary" >
            <xs:attribute name="format" type="TracerBinaryFormat" />
          </xs:extension>
        </xs:simpleContent>
      </xs:complexType>
    </xs:element>
    <xs:element name="adjustment" type="xs:float" minOccurs="0" />
  </xs:sequence>
</xs:complexType>
```

2.5.40 Zernikes

Used in

[IProfilerResult](#)

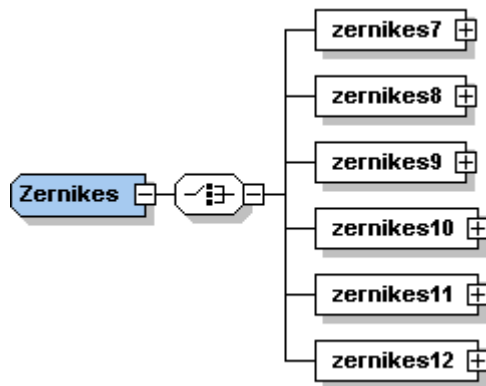

Elemente

zernikes7

type: [Zernikes7](#)
occurs: 1
description:

zernikes8

type: [Zernikes8](#)
occurs: 1
description:

zernikes9

type: [Zernikes9](#)
occurs: 1
description:

zernikes10

type: [Zernikes10](#)
occurs: 1
description:

zernikes11

type: [Zernikes11](#)
occurs: 1
description:

zernikes12

type: [Zernikes12](#)
occurs: 1
description:

XSD

```
<xs:complexType name="Zernikes">
  <xs:choice>
    <xs:element name="zernikes7" type="Zernikes7"/>
    <xs:element name="zernikes8" type="Zernikes8"/>
    <xs:element name="zernikes9" type="Zernikes9"/>
    <xs:element name="zernikes10" type="Zernikes10"/>
    <xs:element name="zernikes11" type="Zernikes11"/>
    <xs:element name="zernikes12" type="Zernikes12"/>
  </xs:choice>
</xs:complexType>
```

2.5.41 Zernikes7

Used in
[Zernikes](#)

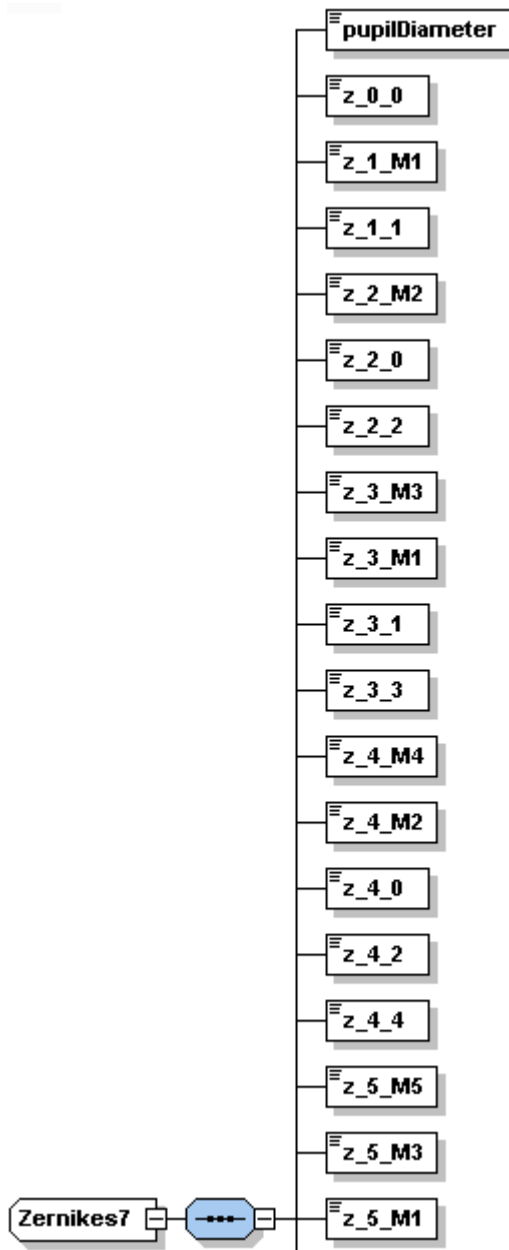

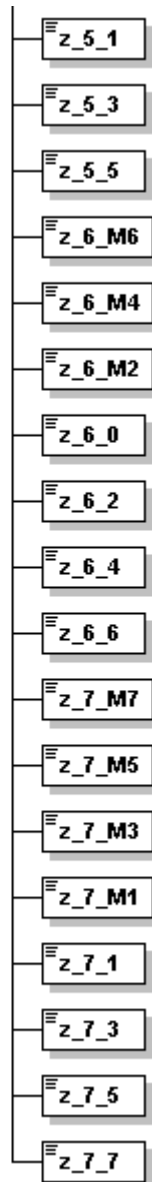

Elemente

pupilDiameter

type: float
unity: mm
occurs: 1
description:

z_1_M1

type: float
unity: μm
occurs: 1
description:

z_1_1

type: float
unity: μm
occurs: 1
description:

z 2 M2

type: float
unity: μm
occurs: 1
description:

z 2 0

type: float
unity: μm
occurs: 1
description:

z 2 2

type: float
unity: μm
occurs: 1
description:

z 3 M3

type: float
unity: μm
occurs: 1
description:

z 3 M1

type: float
unity: μm
occurs: 1
description:

z 3 1

type: float
occurs: 1
unity: μm
description:

z 3 3

type: float
occurs: 1
unity: μm
description:

z 4 M4

type: float
unity: μm
occurs: 1
description:

z 4 M2

type: float
unity: μm
occurs: 1
description:

z 4 0

type: float
unity: μm
occurs: 1
description:

z 4 2

type: float
unity: μm
occurs: 1
description:

z 4 4

type: float
unity: μm
occurs: 1
description:

z 5 M5

type: float
unity: μm
occurs: 1
description:

z 5 M3

type: float
unity: μm
occurs: 1
description:

z 5 M1

type: float
unity: μm
occurs: 1
description:

z 5 1

type: float
unity: μm
occurs: 1
description:

z 5 3

type: float
unity: μm
occurs: 1
description:

z 5 5

type: float
unity: μm
occurs: 1
description:

z 6 M6

type: float
unity: μm
occurs: 1
description:

z 6 M4

type: float
unity: μm
occurs: 1
description:

z 6 M2

type: float
unity: μm
occurs: 1
description:

z 6 0

type: float
unity: μm
occurs: 1
description:

z 6 2

type: float
unity: μm
occurs: 1
description:

z 6 4

type: float
unity: μm
occurs: 1
description:

z 6 6

type: float
unity: μm
occurs: 1
description:

z 7 M7

type: float
unity: μm
occurs: 1
description:

z 7 M5

type: float
unity: μm
occurs: 1
description:

z 7 M3

type: float
unity: μm
occurs: 1
description:

z 7 M1

type: float
unity: μm
occurs: 1
description:

z 7 1

type: float
unity: μm
occurs: 1
description:

z 7 3

type: float
unity: μm
occurs: 1
description:

z 7 5

type: float
unity: μm
occurs: 1
description:

z 7 7

type: float
unity: μm
occurs: 1
description:

XSD

```

<xs:complexType name="Zernikes7">
  <xs:sequence>
    <xs:element name="pupilDiameter" type="xs:float"/>
    <xs:element name="z_0_0" type="xs:float"/>
    <xs:element name="z_1_M1" type="xs:float"/>
    <xs:element name="z_1_1" type="xs:float"/>
    <xs:element name="z_2_M2" type="xs:float"/>
    <xs:element name="z_2_0" type="xs:float"/>
    <xs:element name="z_2_2" type="xs:float"/>
    <xs:element name="z_3_M3" type="xs:float"/>
    <xs:element name="z_3_M1" type="xs:float"/>
  
```

```
<xs:element name="z_3_1" type="xs:float" />
<xs:element name="z_3_3" type="xs:float" />
<xs:element name="z_4_M4" type="xs:float" />
<xs:element name="z_4_M2" type="xs:float" />
<xs:element name="z_4_0" type="xs:float" />
<xs:element name="z_4_2" type="xs:float" />
<xs:element name="z_4_4" type="xs:float" />
<xs:element name="z_5_M5" type="xs:float" />
<xs:element name="z_5_M3" type="xs:float" />
<xs:element name="z_5_M1" type="xs:float" />
<xs:element name="z_5_1" type="xs:float" />
<xs:element name="z_5_3" type="xs:float" />
<xs:element name="z_5_5" type="xs:float" />
<xs:element name="z_6_M6" type="xs:float" />
<xs:element name="z_6_M4" type="xs:float" />
<xs:element name="z_6_M2" type="xs:float" />
<xs:element name="z_6_0" type="xs:float" />
<xs:element name="z_6_2" type="xs:float" />
<xs:element name="z_6_4" type="xs:float" />
<xs:element name="z_6_6" type="xs:float" />
<xs:element name="z_7_M7" type="xs:float" />
<xs:element name="z_7_M3" type="xs:float" />
<xs:element name="z_7_M1" type="xs:float" />
<xs:element name="z_7_M5" type="xs:float" />
<xs:element name="z_7_1" type="xs:float" />
<xs:element name="z_7_3" type="xs:float" />
<xs:element name="z_7_5" type="xs:float" />
<xs:element name="z_7_7" type="xs:float" />
</xs:sequence>
</xs:complexType>
```

2.5.42 Zernikes8

Used in

[Zernikes](#)

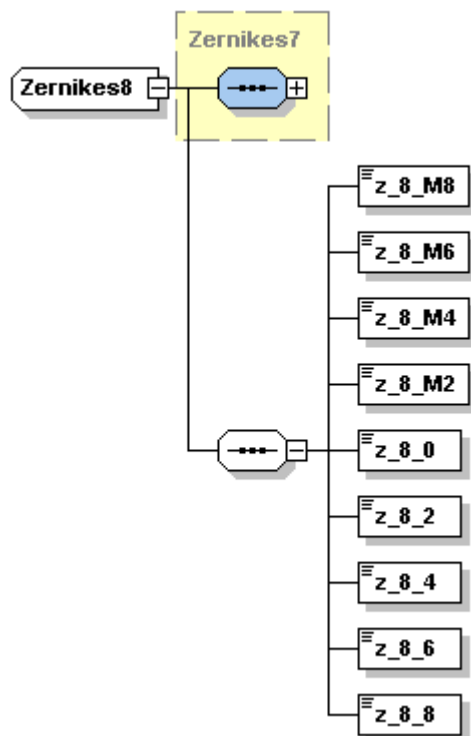

Elemente

z_8_M8

type: float
 unity: μm
 occurs: 1
 description:

z_8_M6

type: float
 unity: μm
 occurs: 1
 description:

z_8_M4

type: float
 unity: μm
 occurs: 1
 description:

z_8_M2

type: float

unity: μm
 occurs: 1
 description:

z 8 0

type: float
 unity: μm
 occurs: 1
 description:

z 8 2

type: float
 unity: μm
 occurs: 1
 description:

z 8 4

type: float
 unity: μm
 occurs: 1
 description:

z 8 6

type: float
 unity: μm
 occurs: 1
 description:

z 8 8

type: float
 unity: μm
 occurs: 1
 description:

XSD

```
<xs:complexType name="Zernikes8">
  <xs:complexContent>
    <xs:extension base="Zernikes7">
      <xs:sequence>
        <xs:element name="z_8_M8" type="xs:float"/>
        <xs:element name="z_8_M6" type="xs:float"/>
        <xs:element name="z_8_M4" type="xs:float"/>
        <xs:element name="z_8_M2" type="xs:float"/>
        <xs:element name="z_8_0" type="xs:float"/>
        <xs:element name="z_8_2" type="xs:float"/>
        <xs:element name="z_8_4" type="xs:float"/>
        <xs:element name="z_8_6" type="xs:float"/>
        <xs:element name="z_8_8" type="xs:float"/>
      </xs:sequence>
    </xs:extension>
  </xs:complexContent>
</xs:complexType>
```

2.5.43 Zernikes9

Used in

[Zernikes](#)

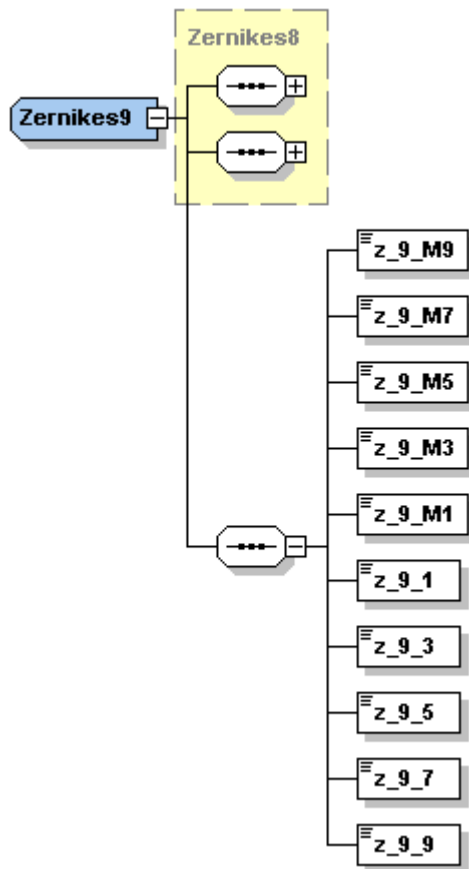

Elemente

z_9_M9

type: float
unity: μm
occurs: 1
description:

z_9_M7

type: float
unity: μm
occurs: 1
description:

z_9_M5

type: float
unity: μm
occurs: 1

description:

z_9_M3

type: float
unity: μm
occurs: 1
description:

z_9_M1

type: float
unity: μm
occurs: 1
description:

z_9_1

type: float
unity: μm
occurs: 1
description:

z_9_3

type: float
unity: μm
occurs: 1
description:

z_9_5

type: float
unity: μm
occurs: 1
description:

z_9_7

type: float
unity: μm
occurs: 1
description:

z_9_9

type: float
unity: μm
occurs: 1
description:

XSD

```
<xs:complexType name="Zernikes9">  
  <xs:complexContent>  
    <xs:extension base="Zernikes8">  
      <xs:sequence>  
        <xs:element name="z_9_M9" type="xs:float"/>  
        <xs:element name="z_9_M7" type="xs:float"/>  
      </xs:sequence>  
    </xs:extension>  
  </xs:complexContent>  
</xs:complexType>
```

```
<xs:element name="z_9_M5" type="xs:float" />
<xs:element name="z_9_M3" type="xs:float" />
<xs:element name="z_9_M1" type="xs:float" />
<xs:element name="z_9_1" type="xs:float" />
<xs:element name="z_9_3" type="xs:float" />
<xs:element name="z_9_5" type="xs:float" />
<xs:element name="z_9_7" type="xs:float" />
<xs:element name="z_9_9" type="xs:float" />
</xs:sequence>
</xs:extension>
</xs:complexContent>
</xs:complexType>
```

2.5.44 Zernikes10

Used in
[Zernikes](#)

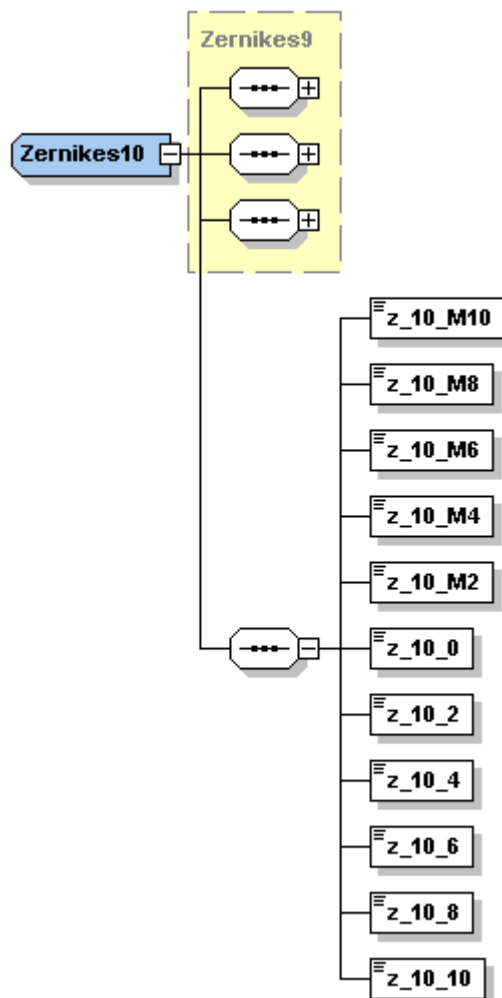

Elemente

z_10_M10

type: float
unity: μm
occurs: 1
description:

z_10_M8

type: float
unity: μm
occurs: 1
description:

z 10 M6

type: float
unity: μm
occurs: 1
description:

z 10 M4

type: float
unity: μm
occurs: 1
description:

z 10 M2

type: float
unity: μm
occurs: 1
description:

z 10 0

type: float
unity: μm
occurs: 1
description:

z 10 2

type: float
unity: μm
occurs: 1
description:

z 10 4

type: float
unity: μm
occurs: 1
description:

z 10 6

type: float
unity: μm
occurs: 1
description:

z 10 8

type: float
unity: μm
occurs: 1
description:

z 10 10

type: float
unity: μm
occurs: 1

description:

XSD

```
<xs:complexType name="Zernikes10">
  <xs:complexContent>
    <xs:extension base="Zernikes9">
      <xs:sequence>
        <xs:element name="z_10_M10" type="xs:float"/>
        <xs:element name="z_10_M8" type="xs:float"/>
        <xs:element name="z_10_M6" type="xs:float"/>
        <xs:element name="z_10_M4" type="xs:float"/>
        <xs:element name="z_10_M2" type="xs:float"/>
        <xs:element name="z_10_0" type="xs:float"/>
        <xs:element name="z_10_2" type="xs:float"/>
        <xs:element name="z_10_4" type="xs:float"/>
        <xs:element name="z_10_6" type="xs:float"/>
        <xs:element name="z_10_8" type="xs:float"/>
        <xs:element name="z_10_10" type="xs:float"/>
      </xs:sequence>
    </xs:extension>
  </xs:complexContent>
</xs:complexType>
```

2.5.45 Zernikes11

Used in
[Zernikes](#)

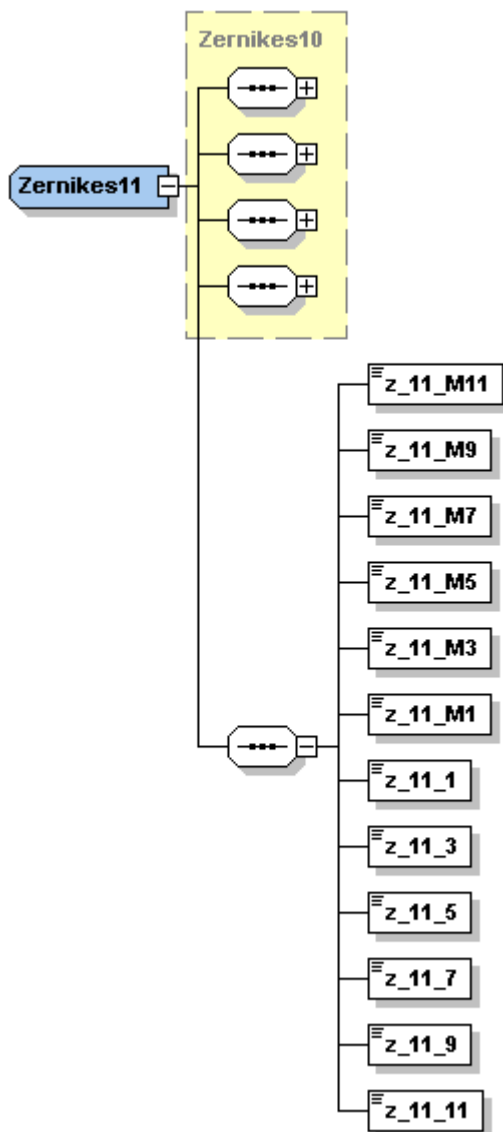

Elemente

z_11_M11

type: float
 unity: μm
 occurs: 1
 description:

z_11_M9

type: float
unity: μm
occurs: 1
description:

z 11 M7

type: float
unity: μm
occurs: 1
description:

z 11 M5

type: float
unity: μm
occurs: 1
description:

z 11 M3

type: float
unity: μm
occurs: 1
description:

z 11 M1

type: float
unity: μm
occurs: 1
description:

z 11 1

type: float
unity: μm
occurs: 1
description:

z 11 3

type: float
unity: μm
occurs: 1
description:

z 11 5

type: float
unity: μm
occurs: 1
description:

z 11 7

type: float
unity: μm
occurs: 1
description:

z_11_9

type: float
unity: μm
occurs: 1
description:

z_11_11

type: float
unity: μm
occurs: 1
description:

XSD

```
<xs:complexType name="Zernikes11">
  <xs:complexContent>
    <xs:extension base="Zernikes10">
      <xs:sequence>
        <xs:element name="z_11_M11" type="xs:float"/>
        <xs:element name="z_11_M9" type="xs:float"/>
        <xs:element name="z_11_M7" type="xs:float"/>
        <xs:element name="z_11_M5" type="xs:float"/>
        <xs:element name="z_11_M3" type="xs:float"/>
        <xs:element name="z_11_M1" type="xs:float"/>
        <xs:element name="z_11_1" type="xs:float"/>
        <xs:element name="z_11_3" type="xs:float"/>
        <xs:element name="z_11_5" type="xs:float"/>
        <xs:element name="z_11_7" type="xs:float"/>
        <xs:element name="z_11_9" type="xs:float"/>
        <xs:element name="z_11_11" type="xs:float"/>
      </xs:sequence>
    </xs:extension>
  </xs:complexContent>
</xs:complexType>
```

2.5.46 Zernikes12

Used in
[Zernikes](#)

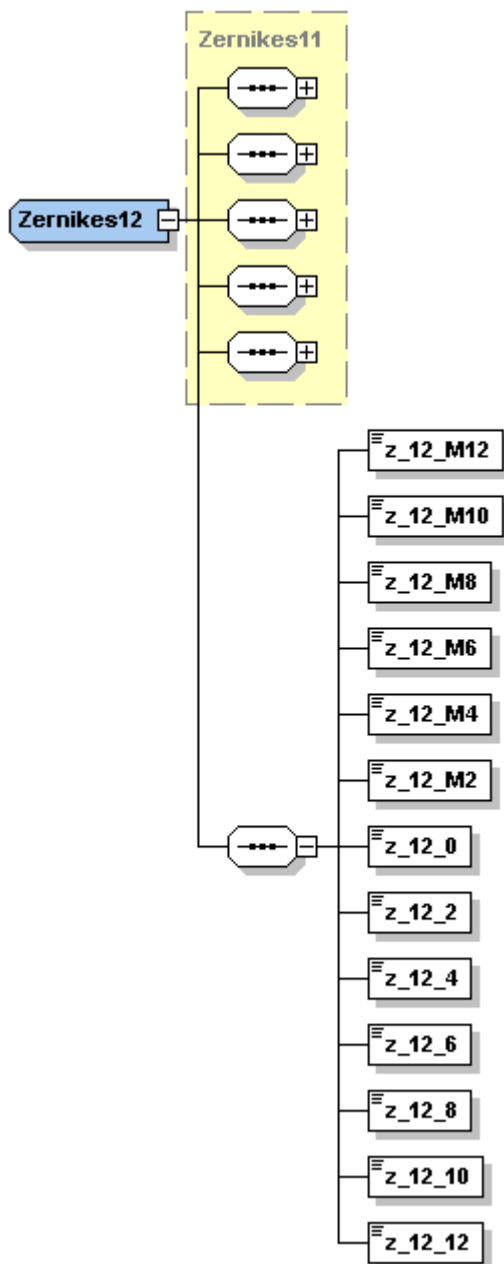

Elemente

z_12_M12

type: float
unity: μm

occurs: 1
description:

z 12 M10

type: float
unity: μm
occurs: 1
description:

z 12 M8

type: float
unity: μm
occurs: 1
description:

z 12 M6

type: float
unity: μm
occurs: 1
description:

z 12 M4

type: float
unity: μm
occurs: 1
description:

z 12 M2

type: float
unity: μm
occurs: 1
description:

z 12 0

type: float
unity: μm
occurs: 1
description:

z 12 2

type: float
unity: μm
occurs: 1
description:

z 12 4

type: float
unity: μm

occurs: 1
description:

z_12_6

type: float
unity: μm
occurs: 1
description:

z_12_8

type: float
unity: μm
occurs: 1
description:

z_12_10

type: float
unity: μm
occurs: 1
description:

z_12_12

type: float
unity: μm
occurs: 1
description:

XSD

```
<xs:complexType name="Zernikes12">
  <xs:complexContent>
    <xs:extension base="Zernikes11">
      <xs:sequence>
        <xs:element name="z_12_M12" type="xs:float"/>
        <xs:element name="z_12_M10" type="xs:float"/>
        <xs:element name="z_12_M8" type="xs:float"/>
        <xs:element name="z_12_M6" type="xs:float"/>
        <xs:element name="z_12_M4" type="xs:float"/>
        <xs:element name="z_12_M2" type="xs:float"/>
        <xs:element name="z_12_0" type="xs:float"/>
        <xs:element name="z_12_2" type="xs:float"/>
        <xs:element name="z_12_4" type="xs:float"/>
        <xs:element name="z_12_6" type="xs:float"/>
        <xs:element name="z_12_8" type="xs:float"/>
        <xs:element name="z_12_10" type="xs:float"/>
        <xs:element name="z_12_12" type="xs:float"/>
      </xs:sequence>
    </xs:extension>
  </xs:complexContent>
</xs:complexType>
```

Chapter



3 XSD - Versionen

3.1 Version 1.2.3

```
<?xml version="1.0" encoding="UTF-8"?>
<!-- edited with XML Spy v4.4 U (http://www.xmlspy.com) by Carl Zeiss (Carl Zeiss) -->
<xs:schema xmlns:xs="http://www.w3.org/2001/XMLSchema" elementFormDefault="qualified"
attributeFormDefault="unqualified" version="1.2.3">
  <xs:element name="b2bOptic">
    <xs:annotation>
      <xs:documentation/>
    </xs:annotation>
    <xs:complexType>
      <xs:sequence>
        <xs:element name="header" type="Header"/>
        <xs:element name="items">
          <xs:complexType>
            <xs:sequence>
              <xs:element name="item" type="Item"
maxOccurs="unbounded"/>
            </xs:sequence>
          </xs:complexType>
        </xs:element>
        <xs:element name="experimental" type="xs:anyType" minOccurs
="0" maxOccurs="unbounded"/>
      </xs:sequence>
    </xs:complexType>
  </xs:element>
  <xs:simpleType name="MsgTypes">
    <xs:restriction base="xs:string">
      <xs:enumeration value="ORDER"/>
      <xs:enumeration value="REQUEST"/>
      <xs:enumeration value="CALCULATION"/>
      <xs:enumeration value="VALIDATION"/>
    </xs:restriction>
  </xs:simpleType>
  <xs:simpleType name="BevelPosType">
    <xs:restriction base="xs:string">
      <xs:enumeration value="AUTO"/>
      <xs:enumeration value="FRONT"/>
      <xs:enumeration value="BACK"/>
      <xs:enumeration value="RELATION"/>
    </xs:restriction>
  </xs:simpleType>
  <xs:simpleType name="BevelTypes">
    <xs:restriction base="xs:string">
      <xs:enumeration value="NORMAL"/>
      <xs:enumeration value="FLAT"/>
      <xs:enumeration value="GROOVED"/>
    </xs:restriction>
  </xs:simpleType>
  <xs:simpleType name="SoftwareTypes">
    <xs:restriction base="xs:string">
      <xs:enumeration value="ORIGINATOR"/>
      <xs:enumeration value="VERIFIER"/>
      <xs:enumeration value="SENDER"/>
    </xs:restriction>
  </xs:simpleType>
  <xs:simpleType name="MsgStates">
    <xs:restriction base="xs:string">
      <xs:enumeration value="NEW"/>
      <xs:enumeration value="UPDATE"/>
      <xs:enumeration value="CANCEL"/>
    </xs:restriction>
  </xs:simpleType>
  <xs:simpleType name="MsgSteps">
    <xs:restriction base="xs:string">
      <xs:enumeration value="CREATE"/>
      <xs:enumeration value="TRANSFER"/>
      <xs:enumeration value="RECEIPT"/>
    </xs:restriction>
  </xs:simpleType>
  <xs:simpleType name="Roles">
```

```

        <xs:restriction base="xs:string">
            <xs:enumeration value="ORIGINATOR" />
            <xs:enumeration value="SUPPLIER" />
            <xs:enumeration value="SHIPTO" />
            <xs:enumeration value="CARRIER" />
            <xs:enumeration value="INVOICETO" />
            <xs:enumeration value="PAIDBY" />
            <xs:enumeration value="MANUFACTURER" />
        </xs:restriction>
    </xs:simpleType>
    <xs:simpleType name="FrameMaterials">
        <xs:restriction base="xs:string">
            <xs:enumeration value="METAL" />
            <xs:enumeration value="PLASTIC" />
            <xs:enumeration value="OPTYL" />
            <xs:enumeration value="NYLOR" />
            <xs:enumeration value="DRILLED" />
            <xs:enumeration value="SPECIAL" />
        </xs:restriction>
    </xs:simpleType>
    <xs:simpleType name="HeightReferences">
        <xs:restriction base="xs:string">
            <xs:enumeration value="OVERBOX" />
            <xs:enumeration value="OVERSHAPE" />
        </xs:restriction>
    </xs:simpleType>
    <xs:simpleType name="OCReferences">
        <xs:restriction base="xs:string">
            <xs:enumeration value="FAR" />
            <xs:enumeration value="NEAR" />
        </xs:restriction>
    </xs:simpleType>
    <xs:simpleType name="CoatingTypes">
        <xs:restriction base="xs:string">
            <xs:enumeration value="COLOR" />
            <xs:enumeration value="UV" />
            <xs:enumeration value="ANTIREFLEX" />
            <xs:enumeration value="HARD" />
            <xs:enumeration value="CLEAN" />
            <xs:enumeration value="OTHER" />
        </xs:restriction>
    </xs:simpleType>
    <xs:simpleType name="EdgingType">
        <xs:restriction base="xs:string">
            <xs:enumeration value="NONE" />
            <xs:enumeration value="ROUGHING" />
            <xs:enumeration value="ONSHAPE" />
            <xs:enumeration value="GIVENFRAME" />
            <xs:enumeration value="ORDEREDFRAME" />
        </xs:restriction>
    </xs:simpleType>
    <xs:simpleType name="AngleDimension">
        <xs:restriction base="xs:string">
            <xs:enumeration value="DEG" />
            <xs:enumeration value="RAD" />
            <xs:enumeration value="MM" />
        </xs:restriction>
    </xs:simpleType>
    <xs:simpleType name="Currencies">
        <xs:restriction base="xs:string">
            <xs:length value="3" />
            <xs:enumeration value="EUR" />
            <xs:enumeration value="USD" />
            <xs:enumeration value="SFR" />
        </xs:restriction>
    </xs:simpleType>
    <xs:simpleType name="Sides">
        <xs:restriction base="xs:string">
            <xs:enumeration value="RIGHT" />
            <xs:enumeration value="LEFT" />
            <xs:enumeration value="UNDEFINED" />
        </xs:restriction>
    </xs:simpleType>
    <xs:simpleType name="ThicknessReferences">
        <xs:restriction base="xs:string">

```

```

        <xs:enumeration value="REDUCEWITHSHAPE" />
        <xs:enumeration value="CENTER" />
        <xs:enumeration value="EDGE" />
        <xs:enumeration value="DRILLHOLE" />
        <xs:enumeration value="FORNYLOR" />
        <xs:enumeration value="THIN" />
    </xs:restriction>
</xs:simpleType>
<xs:simpleType name="DeliveryMethods">
    <xs:restriction base="xs:string" />
</xs:simpleType>
<xs:simpleType name="References">
    <xs:restriction base="xs:string">
        <xs:enumeration value="BOXCENTER" />
        <xs:enumeration value="OPTCENTER" />
    </xs:restriction>
</xs:simpleType>
<xs:complexType name="TimeStamps">
    <xs:sequence>
        <xs:element name="dateTime">
            <xs:complexType>
                <xs:simpleContent>
                    <xs:extension base="xs:dateTime">
                        <xs:attribute name="step" type="
MsgSteps" use="required" />
                    </xs:extension>
                </xs:simpleContent>
            </xs:complexType>
        </xs:element>
    </xs:sequence>
</xs:complexType>
<xs:complexType name="CurrencyValue">
    <xs:sequence>
        <xs:element name="Value" form="qualified">
            <xs:complexType>
                <xs:simpleContent>
                    <xs:extension base="xs:float">
                        <xs:attribute name="currency" type="
Currencies" use="required" />
                    </xs:extension>
                </xs:simpleContent>
            </xs:complexType>
        </xs:element>
    </xs:sequence>
</xs:complexType>
<xs:complexType name="Software">
    <xs:sequence>
        <xs:element name="name" type="xs:string" />
        <xs:element name="version" type="xs:string" />
    </xs:sequence>
    <xs:attribute name="typeOf" type="SoftwareTypes" use="required" />
</xs:complexType>
<xs:complexType name="ProductCatalog">
    <xs:sequence>
        <xs:element name="name" type="xs:string">
            <xs:annotation>
                <xs:documentation>i.e. "IPRO STANDARD": currently
ignored</xs:documentation>
            </xs:annotation>
        </xs:element>
        <xs:element name="version" type="xs:string">
            <xs:annotation>
                <xs:documentation>i.e. "6.2": currently ignored</
xs:documentation>
            </xs:annotation>
        </xs:element>
        <xs:element name="release" type="xs:string">
            <xs:annotation>
                <xs:documentation>when was the catalogue released or
a release-version: currently ignored</xs:documentation>
            </xs:annotation>
        </xs:element>
    </xs:sequence>
</xs:complexType>
<xs:complexType name="Account">

```

```

        <xs:sequence>
          <xs:element name="id">
            <xs:complexType>
              <xs:simpleContent>
                <xs:extension base="xs:string">
                  <xs:attribute name="memberShipID" type
="xs:long" use="optional" default="1">
                    <xs:annotation>
                      <xs:documentation>CZ:
For further use: Specify the membership-id to support different customerid's for different
brands.</xs:documentation>
                    </xs:annotation>
                  </xs:attribute>
                </xs:extension>
              </xs:simpleContent>
            </xs:complexType>
          </xs:element>
          <xs:element name="name" type="xs:string" minOccurs="0">
            <xs:annotation>
              <xs:documentation>CZ: currently ignored</
xs:documentation>
            </xs:annotation>
          </xs:element>
          <xs:element name="address" type="Address" minOccurs="0">
            <xs:annotation>
              <xs:documentation>CZ: currently ignored</
xs:documentation>
            </xs:annotation>
          </xs:element>
          <xs:element name="contact" type="ContactInfo" minOccurs="0">
            <xs:annotation>
              <xs:documentation>CZ: currently ignored</
xs:documentation>
            </xs:annotation>
          </xs:element>
        </xs:sequence>
      </xs:complexType>
      <xs:complexType name="Address">
        <xs:sequence>
          <xs:element name="addressLine" type="xs:string" minOccurs="0"
maxOccurs="3"/>
          <xs:element name="poBox" type="xs:string" minOccurs="0"/>
          <xs:choice minOccurs="0">
            <xs:element name="province" type="xs:string"/>
            <xs:element name="region" type="xs:string"/>
            <xs:element name="state" type="xs:string"/>
          </xs:choice>
          <xs:element name="city" type="xs:string"/>
          <xs:element name="zip" type="xs:string"/>
          <xs:element name="countryCode" type="xs:string"/>
        </xs:sequence>
      </xs:complexType>
      <xs:complexType name="ContactInfo">
        <xs:sequence>
          <xs:element name="title" type="xs:string" minOccurs="0"/>
          <xs:element name="firstName" type="xs:string" minOccurs="0"/>
          <xs:element name="lastName" type="xs:string"/>
          <xs:element name="phone" type="xs:string" minOccurs="0" maxOccurs="
unbounded"/>
          <xs:element name="fax" type="xs:string" minOccurs="0" maxOccurs="
unbounded"/>
          <xs:element name="eMail" type="xs:string" minOccurs="0" maxOccurs="
unbounded"/>
        </xs:sequence>
      </xs:complexType>
      <xs:complexType name="Lens">
        <xs:sequence>
          <xs:element name="commercialCode" type="xs:string"/>
          <xs:choice>
            <xs:sequence>
              <xs:element name="rxData">
                <xs:complexType>
                  <xs:complexContent>
                    <xs:extension base="RXDataType
"/>

```



```

        </xs:complexContent>
      </xs:complexType>
    </xs:element>
    <xs:element name="coating" minOccurs="0" maxOccurs="
unbounded">
      <xs:complexType>
        <xs:sequence>
          <xs:element name="
commercialCode" type="xs:string"/>
          <xs:element name="minIntensity"
            type="xs:integer" minOccurs="0">
              <xs:annotation>
                <
xs:documentation>Minimum color intensity for tinting as a percentage: currently ignored</
xs:documentation>
              </xs:annotation>
            </xs:element>
          <xs:element name="maxIntensity"
            type="xs:integer" minOccurs="0">
              <xs:annotation>
                <
xs:documentation>Maximum color intensity for tinting as a percentage: currently ignored</
xs:documentation>
              </xs:annotation>
            </xs:element>
        </xs:sequence>
        <xs:attribute name="coatingType" type
="CoatingTypes" use="optional"/>
      </xs:complexType>
    </xs:element>
    <xs:element name="centration" type="Centration"
minOccurs="0"/>
      <xs:element name="geometry" type="GeometryType"/>
      <xs:element name="options" minOccurs="0">
        <xs:complexType>
          <xs:sequence>
            <xs:choice minOccurs="0">
              <xs:element name="
occlusion" type="xs:boolean"/>
              <xs:element name="
frosted" type="xs:boolean">
                <xs:annotation>
                  <
xs:documentation>mattieren</xs:documentation>
                </xs:annotation>
              </xs:choice>
            <xs:element name="slabOff"
              type="xs:complexType"
              <
xs:simpleContent>
                <xs:extension base="xs:boolean">
                  <xs:attribute name="value" use="optional">
                    <xs:simpleType>
                      <xs:restriction base="xs:float">
                        <xs:minInclusive value="1.3"/>
                      </xs:restriction>
                    </xs:simpleType>
                  </xs:attribute>
                </xs:extension>
              </xs:simpleContent>
            </xs:complexType>
          </xs:element>

```



```

<xs:attribute name="side" type="Sides" use="required"/>
<xs:attribute name="balancingLens" type="xs:boolean" use="optional" default
="0"/>
<xs:attribute name="virtualLens" type="xs:boolean" use="optional" default="
0">
    <xs:annotation>
        <xs:documentation>CZ: currently ignored</xs:documentation>
    </xs:annotation>
</xs:attribute>
</xs:complexType>
<xs:complexType name="StockLens">
    <xs:sequence>
        <xs:element name="commercialCode" type="xs:string"/>
        <xs:element name="rxData" type="RXDataType4SL"/>
        <xs:element name="coating" minOccurs="0" maxOccurs="unbounded">
            <xs:complexType>
                <xs:sequence>
                    <xs:element name="commercialCode"/>
                    <xs:element name="minIntensity" type="
xs:integer" minOccurs="0">
                        <xs:annotation>
                            <xs:documentation>Minimum
color intensity for tinting as a percentage</xs:documentation>
                        </xs:annotation>
                    </xs:element>
                    <xs:element name="maxIntensity" type="
xs:integer" minOccurs="0">
                        <xs:annotation>
                            <xs:documentation>Maximum
color intensity for tinting as a percentage</xs:documentation>
                        </xs:annotation>
                    </xs:element>
                </xs:sequence>
                <xs:attribute name="coatingType" type="CoatingTypes"
use="optional"/>
            </xs:complexType>
        </xs:element>
        <xs:element name="diameter">
            <xs:complexType>
                <xs:sequence>
                    <xs:element name="physical">
                        <xs:simpleType>
                            <xs:restriction base="
xs:integer">
                                <xs:minInclusive value
="1"/>
                                <xs:maxInclusive value
="99"/>
                            </xs:restriction>
                        </xs:simpleType>
                    </xs:element>
                    <xs:element name="optical" minOccurs="0">
                        <xs:annotation>
                            <xs:documentation>only if
predecentrated</xs:documentation>
                        </xs:annotation>
                        <xs:simpleType>
                            <xs:restriction base="
xs:integer">
                                <xs:minInclusive value
="1"/>
                                <xs:maxInclusive value
="99"/>
                            </xs:restriction>
                        </xs:simpleType>
                    </xs:element>
                </xs:sequence>
            </xs:complexType>
        </xs:element>
    </xs:sequence>
</xs:complexType>
<xs:complexType name="RXDataType">
    <xs:choice>
        <xs:sequence>
            <xs:element name="sphere">

```

```

        <xs:simpleType>
          <xs:restriction base="xs:float">
            <xs:minInclusive value="-50"/>
            <xs:maxInclusive value="50"/>
          </xs:restriction>
        </xs:simpleType>
      </xs:element>
    </xs:sequence>
  </xs:complexType>
  <xs:element name="cylinder" type="Cylinder" minOccurs="0"/>
  <xs:element name="addition" minOccurs="0">
    <xs:simpleType>
      <xs:restriction base="xs:float">
        <xs:minInclusive value="0.25"/>
      </xs:restriction>
    </xs:simpleType>
  </xs:element>
  <xs:element name="prism" minOccurs="0" maxOccurs="2">
    <xs:complexType>
      <xs:complexContent>
        <xs:extension base="Prism">
          <xs:attribute name="
pupillary-distance-correction" use="optional">
          </xs:attribute>
        </xs:extension>
      </xs:complexContent>
    </xs:complexType>
  </xs:element>
  </xs:sequence>
  <xs:element name="trialFrame" type="TrialFrame">
    <xs:annotation>
      <xs:documentation>centration data needed: currently
ignored</xs:documentation>
    </xs:annotation>
  </xs:element>
</xs:choice>
</xs:complexType>
<xs:complexType name="RXDataType4SL">
  <xs:sequence>
    <xs:element name="sphere">
      <xs:simpleType>
        <xs:restriction base="xs:float">
          <xs:minInclusive value="-50"/>
          <xs:maxInclusive value="50"/>
        </xs:restriction>
      </xs:simpleType>
    </xs:element>
    <xs:element name="cylinder" type="Cylinder" minOccurs="0"/>
    <xs:element name="addition" minOccurs="0">
      <xs:simpleType>
        <xs:restriction base="xs:float">
          <xs:minInclusive value="0.25"/>
        </xs:restriction>
      </xs:simpleType>
    </xs:element>
  </xs:sequence>
</xs:complexType>
<xs:complexType name="Centration">
  <xs:sequence>
    <xs:element name="monocularCentrationDistance">
      <xs:annotation>
        <xs:documentation>CZ: see @reference annotation</
xs:documentation>
      </xs:annotation>
    </xs:element>
  </xs:sequence>
</xs:complexType>

```

```

        <xs:simpleContent>
            <xs:extension base="xs:float">
                <xs:attribute name="reference" type="
OCReferences" use="required">
                    <xs:annotation>
                        <xs:documentation>CZ:
Currently only FAR supported, NEAR will be ignored!</xs:documentation>
                    </xs:annotation>
                </xs:attribute>
            </xs:extension>
        </xs:simpleContent>
    </xs:complexType>
</xs:element>
<xs:element name="height">
    <xs:annotation>
        <xs:documentation>CZ: see @reference annotation</
xs:documentation>
    </xs:annotation>
</xs:complexType>
    <xs:simpleContent>
        <xs:extension base="xs:float">
            <xs:attribute name="reference" type="
OCReferences" use="required">
                <xs:annotation>
                    <xs:documentation>FAR -
> Y-> H</xs:documentation>
                </xs:annotation>
            </xs:attribute>
            <xs:attribute name="referenceHeight"
type="HeightReferences" use="required"/>
        </xs:extension>
    </xs:simpleContent>
</xs:complexType>
</xs:element>
<xs:element name="backVertexDistance" minOccurs="0">
    <xs:complexType>
        <xs:simpleContent>
            <xs:extension base="xs:float"/>
        </xs:simpleContent>
    </xs:complexType>
</xs:element>
</xs:sequence>
</xs:complexType>
<xs:complexType name="Shape">
    <xs:sequence>
        <xs:element name="perimeter" type="xs:float">
            <xs:annotation>
                <xs:documentation>CZ: currently ignored</
xs:documentation>
            </xs:annotation>
        </xs:element>
        <xs:element name="points">
            <xs:complexType>
                <xs:choice>
                    <xs:element name="pPoints" type="PPoint"
minOccurs="18" maxOccurs="unbounded">
                        <xs:annotation>
                            <xs:documentation>CZ: In an
order (header[@msgType=ORDER]) any number of polar coordinates other than 36 will result
in an exception thrown to the client. YOU HAVE BEEN WARNED!</xs:documentation>
                        </xs:annotation>
                    </xs:element>
                    <xs:element name="cPoints" type="CPoint"
minOccurs="18" maxOccurs="unbounded">
                        <xs:annotation>
                            <xs:documentation>CZ:
currently ignored - use polar coordinates instead!</xs:documentation>
                        </xs:annotation>
                    </xs:element>
                </xs:choice>
            </xs:complexType>
            <xs:attribute name="dimensions" type="xs:integer" use
="required"/>
            <xs:attribute name="reference" type="References" use
="optional"/>
        </xs:complexType>

```

```

        </xs:element>
      </xs:sequence>
    </xs:complexType>
  <xs:complexType name="CPoint">
    <xs:sequence>
      <xs:element name="x" type="xs:float">
        <xs:annotation>
          <xs:documentation>mm</xs:documentation>
        </xs:annotation>
      </xs:element>
      <xs:element name="y" type="xs:float">
        <xs:annotation>
          <xs:documentation>mm</xs:documentation>
        </xs:annotation>
      </xs:element>
      <xs:element name="z" type="xs:float" minOccurs="0">
        <xs:annotation>
          <xs:documentation>mm</xs:documentation>
        </xs:annotation>
      </xs:element>
    </xs:sequence>
  </xs:complexType>
  <xs:complexType name="PPoint">
    <xs:sequence>
      <xs:element name="angle">
        <xs:complexType>
          <xs:simpleContent>
            <xs:extension base="xs:float">
              <xs:attribute name="dimension" type="
AngleDimension" use="optional" default="DEG"/>
            </xs:extension>
          </xs:simpleContent>
        </xs:complexType>
      </xs:element>
      <xs:element name="radius" type="xs:float">
        <xs:annotation>
          <xs:documentation>mm</xs:documentation>
        </xs:annotation>
      </xs:element>
      <xs:element name="z" type="xs:float" minOccurs="0">
        <xs:annotation>
          <xs:documentation>mm: currently ignored</
xs:documentation>
        </xs:annotation>
      </xs:element>
    </xs:sequence>
  </xs:complexType>
  <xs:complexType name="Size">
    <xs:sequence>
      <xs:element name="width" type="xs:float"/>
      <xs:element name="height" type="xs:float"/>
      <xs:element name="bridge" type="xs:float"/>
      <xs:element name="templeLength" type="xs:float" minOccurs="0"/>
    </xs:sequence>
  </xs:complexType>
  <xs:complexType name="Bevel">
    <xs:sequence>
      <xs:element name="type" type="BevelTypes"/>
      <xs:element name="position" minOccurs="0" maxOccurs="2">
        <xs:annotation>
          <xs:documentation>in case of FRONT, BACK: [mm]
distance to front/back. In case of RELATED: [%] front/back-dist.
</xs:documentation>
        </xs:annotation>
      </xs:element>
    </xs:sequence>
  </xs:complexType>
  <xs:complexType name="BevelPosType">
    <xs:simpleContent>
      <xs:extension base="xs:float">
        <xs:attribute name="posType" type="
BevelPosType" use="optional" default="AUTO"/>
        <xs:attribute name="side" type="Sides"
use="optional"/>
      </xs:extension>
    </xs:simpleContent>
  </xs:complexType>
</xs:element>

```

```
<xs:element name="grooveDepth" type="xs:float" minOccurs="0">
  <xs:annotation>
    <xs:documentation>CZ: currently ignored</
xs:documentation>
    </xs:annotation>
  </xs:element>
  <xs:element name="grooveWidth" type="xs:float" minOccurs="0">
    <xs:annotation>
      <xs:documentation>CZ: currently ignored</
xs:documentation>
      </xs:annotation>
    </xs:element>
  </xs:sequence>
</xs:complexType>
<xs:complexType name="Curve">
  <xs:choice>
    <xs:element name="flat" type="xs:boolean"/>
    <xs:element name="moreCurved" type="xs:boolean">
      <xs:annotation>
        <xs:documentation>CZ: currently ignored</
xs:documentation>
        </xs:annotation>
      </xs:element>
    <xs:element name="baseCurve" type="xs:float">
      <xs:annotation>
        <xs:documentation>CZ: currently ignored</
xs:documentation>
        </xs:annotation>
      </xs:element>
    <xs:element name="planoConcave" type="xs:boolean">
      <xs:annotation>
        <xs:documentation>CZ: currently ignored</
xs:documentation>
        </xs:annotation>
      </xs:element>
    <xs:element name="planoConvex" type="xs:boolean">
      <xs:annotation>
        <xs:documentation>CZ: currently ignored</
xs:documentation>
        </xs:annotation>
      </xs:element>
    <xs:element name="biConcave" type="xs:boolean">
      <xs:annotation>
        <xs:documentation>CZ: currently ignored</
xs:documentation>
        </xs:annotation>
      </xs:element>
    <xs:element name="biConvex" type="xs:boolean">
      <xs:annotation>
        <xs:documentation>CZ: currently ignored</
xs:documentation>
        </xs:annotation>
      </xs:element>
  </xs:choice>
</xs:complexType>
<xs:complexType name="Header">
  <xs:sequence>
    <xs:element name="cultureId" type="xs:string">
      <xs:annotation>
        <xs:documentation>CZ: currently ignored</
xs:documentation>
        </xs:annotation>
      </xs:element>
    <xs:element name="customersOrderId" type="xs:string">
      <xs:annotation>
        <xs:documentation>CZ: currently ignored</
xs:documentation>
        </xs:annotation>
      </xs:element>
    <xs:element name="distributorsOrderId" type="xs:string">
      <xs:annotation>
        <xs:documentation>CZ: currently ignored</
xs:documentation>
        </xs:annotation>
      </xs:element>
  </xs:sequence>
</xs:complexType>
```

```

        <xs:element name="timeStamps" type="TimeStamps" maxOccurs="unbounded"
">
            <xs:annotation>
                <xs:documentation>CZ: currently ignored</
xs:documentation>
            </xs:annotation>
        </xs:element>
        <xs:element name="remark" type="xs:string" minOccurs="0">
            <xs:annotation>
                <xs:documentation>CZ: Any comments or remarks are
effectively ignored!</xs:documentation>
            </xs:annotation>
        </xs:element>
        <xs:element name="orderParties" maxOccurs="unbounded">
            <xs:annotation>
                <xs:documentation>CZ: at least one entry with @role
ORIGINATOR or INVOICETO should be present, unless present under items/parties; serves as
default - if nothing is specified in items branch, these entries are used</
xs:documentation>
            </xs:annotation>
            <xs:complexType>
                <xs:complexContent>
                    <xs:extension base="Account">
                        <xs:attribute name="role" type="Roles"
use="required"/>
                    </xs:extension>
                </xs:complexContent>
            </xs:complexType>
            <xs:element name="software" type="Software" maxOccurs="unbounded"/>
            <xs:element name="productCatalog" type="ProductCatalog"/>
            <xs:element name="portalOrderId" type="xs:string">
                <xs:annotation>
                    <xs:documentation>retailer's order id: currently
ignored</xs:documentation>
                </xs:annotation>
            </xs:element>
        </xs:sequence>
        <xs:attribute name="msgType" type="MsgTypes" use="optional" default="
REQUEST"/>
        <xs:attribute name="msgState" type="MsgStates" use="optional" default="NEW
"/>
        <xs:attribute name="testIndicator" type="xs:boolean" use="optional" default
="0"/>
    </xs:complexType>
    <xs:complexType name="Item">
        <xs:sequence>
            <xs:element name="remark" type="xs:string" minOccurs="0">
                <xs:annotation>
                    <xs:documentation>CZ: Any comments or remarks are
effectively ignored!</xs:documentation>
                </xs:annotation>
            </xs:element>
            <xs:element name="parties" minOccurs="0" maxOccurs="unbounded">
                <xs:annotation>
                    <xs:documentation>if not given use defaults from
header: selection rules:
@role ORIGINATOR will receive invoice if no @role INVOICETO is presentno @role SHIPTO is
present, the recipient of the invoice will also become recipient of the goods</
xs:documentation>
                </xs:annotation>
            </xs:complexType>
                <xs:complexContent>
                    <xs:extension base="Account">
                        <xs:attribute name="role" type="Roles"
use="required"/>
                    </xs:extension>
                </xs:complexContent>
            </xs:complexType>
            <xs:element name="referenceNo" type="xs:string">
                <xs:annotation>
                    <xs:documentation>i.e. buyer's job no.</
xs:documentation>
                </xs:annotation>
            </xs:element>
        </xs:sequence>
    </xs:complexType>

```



```

        </xs:element>
        <xs:element name="referenceText" type="xs:string" minOccurs="0">
          <xs:annotation>
            <xs:documentation>i.e. buyer's commission: currently
ignored - use referenceNo also for textual references (commission)</xs:documentation>
          </xs:annotation>
        </xs:element>
        <xs:element name="requestedDate" type="xs:date" minOccurs="0">
          <xs:annotation>
            <xs:documentation>CZ: currently ignored</
xs:documentation>
          </xs:annotation>
        </xs:element>
        <xs:element name="deliveryMethod">
          <xs:annotation>
            <xs:documentation>CZ: currently ignored</
xs:documentation>
          </xs:annotation>
          <xs:complexType>
            <xs:simpleContent>
              <xs:extension base="xs:string">
                <xs:attribute name="deliveryType" type
="DeliveryMethods" use="optional">
                  <xs:annotation>
                    <xs:documentation>
enumeration of predefined methodes
                  </xs:documentation>
                </xs:annotation>
              </xs:extension>
            </xs:simpleContent>
          </xs:complexType>
        </xs:element>
        <xs:element name="manufacturer" type="xs:string">
          <xs:annotation>
            <xs:documentation>CZ: currently ignored</
xs:documentation>
          </xs:annotation>
        </xs:element>
        <xs:choice>
          <xs:element name="pair" type="Pair"/>
          <xs:element name="stockLens">
            <xs:annotation>
              <xs:documentation>CZ: currently ignored</
xs:documentation>
            </xs:annotation>
            <xs:complexType>
              <xs:complexContent>
                <xs:extension base="StockLens">
                  <xs:attribute name="quantity"
type="xs:integer" use="required"/>
                  <xs:attribute name="side" type
="Sides" use="required"/>
                </xs:extension>
              </xs:complexContent>
            </xs:complexType>
          </xs:element>
          <xs:element name="semi">
            <xs:annotation>
              <xs:documentation>CZ: currently ignored</
xs:documentation>
            </xs:annotation>
            </xs:element>
          </xs:choice>
        <xs:element name="options" minOccurs="0">
          <xs:annotation>
            <xs:documentation>CZ: currently ignored</
xs:documentation>
          </xs:annotation>
          <xs:complexType>
            <xs:sequence>
              <xs:element name="insurance" type="xs:integer
" minOccurs="0"/>
            </xs:sequence>
          </xs:complexType>

```

```

        </xs:element>
      </xs:sequence>
    </xs:complexType>
  <xs:complexType name="Frame">
    <xs:sequence>
      <xs:element name="material" type="FrameMaterials">
        <xs:annotation>
          <xs:documentation>CZ: currently recognized: METAL,
PLASTIC, NYLOR, SPECIAL</xs:documentation>
        </xs:annotation>
      </xs:element>
      <xs:element name="manufacturer" type="xs:string" minOccurs="0"/>
      <xs:element name="brand" type="xs:string" minOccurs="0">
        <xs:annotation>
          <xs:documentation>CZ: currently ignored</
xs:documentation>
        </xs:annotation>
      </xs:element>
      <xs:element name="model" type="xs:string" minOccurs="0"/>
      <xs:element name="size" type="Size" minOccurs="0">
        <xs:annotation>
          <xs:documentation>Nominal size information as given
from frame manufacturer: currently ignored - use size elements under shape!</
xs:documentation>
        </xs:annotation>
      </xs:element>
      <xs:element name="color" type="xs:string" minOccurs="0">
        <xs:annotation>
          <xs:documentation>CZ: currently ignored</
xs:documentation>
        </xs:annotation>
      </xs:element>
      <xs:element name="commercialCode" type="xs:string" minOccurs="0">
        <xs:annotation>
          <xs:documentation>CZ: currently ignored</
xs:documentation>
        </xs:annotation>
      </xs:element>
      <xs:element name="shape" minOccurs="0">
        <xs:complexType>
          <xs:sequence>
            <xs:choice>
              <xs:element name="catalog">
                <xs:annotation>
                  <xs:documentation>for
thicknessreduction: currently ignored</xs:documentation>
                </xs:annotation>
              </xs:element>
              <xs:sequence>
                <xs:element
name="shapeId" type="xs:string"/>
              </xs:sequence>
            </xs:choice>
          </xs:complexType>
        </xs:element>
        <xs:element name="explicit" type="
Shape" maxOccurs="2">
          <xs:annotation>
            <xs:documentation>CZ:
If explicit occurs once, data is assumed to belong to the right lens - no matter if there
is only a right lens, only a left lens or two lenses in the document. If explicit occurs
twice, the first occurrence is assumed to belong to the right lens, the second to the left
lens respectively - again no matter how many lenses are really contained in the document
under pair/lens</xs:documentation>
          </xs:annotation>
        </xs:element>
        <xs:element name="tracerData">
          <xs:annotation>
            <xs:documentation>
necessary for remoteEdging/Presize</xs:documentation>
          </xs:annotation>
        </xs:complexType>
      </xs:sequence>
    </xs:element>
    name="tracerBrand" type="xs:string">

```

<

```
xs:annotation>
<xs:documentation>i.e. "Briot", "Essilor", "Nidek"</xs:documentation>
xs:annotation>
name="tracerType">
xs:annotation>
<xs:documentation>i.e. "Scanform Net 2", "Phi": currently ignored</xs:documentation>
xs:annotation>
xs:simpleType>
<xs:restriction base="xs:string">
  <xs:enumeration value="Hoya 3DFT"/>
  <xs:enumeration value="Hoya GT1000"/>
  <xs:enumeration value="Hoya GT3000"/>
  <xs:enumeration value="Hoya GT3000 OMA"/>
  <xs:enumeration value="Hoya UT1000"/>
  <xs:enumeration value="Essilor Gamma"/>
  <xs:enumeration value="Essilor PHI PCCOM"/>
  <xs:enumeration value="Essilor PHI OMA"/>
  <xs:enumeration value="Essilor Kappa PCCOM"/>
  <xs:enumeration value="Essilor Kappa OMA"/>
  <xs:enumeration value="National Optronics 4T"/>
  <xs:enumeration value="Briot ScanfomNet I"/>
  <xs:enumeration value="Briot ScanfomNet II"/>
  <xs:enumeration value="Weco 3DFT+"/>
  <xs:enumeration value="Weco Trace II"/>
  <xs:enumeration value="Weco Trace III"/>
  <xs:enumeration value="Nidek LT700"/>
  <xs:enumeration value="Nidek LT900"/>
  <xs:enumeration value="Nidek LT1000"/>
  <xs:enumeration value="Indo NDK"/>
  <xs:enumeration value="Indo OMA"/>
  <xs:enumeration value="Topcon FR50"/>
  <xs:enumeration value="Takubomatic FD80"/>
  <xs:enumeration value="Unknown"/>
</xs:restriction>
xs:simpleType>
name="tracerVersion" type="xs:string">
xs:annotation>
```

```

<xs:documentation>CZ: currently ignored</xs:documentation>
xs:annotation>
</xs:element>
name="tracerID" type="xs:string" minOccurs="0">
<xs:documentation>CZ: Serial number of the tracer</xs:documentation>
xs:annotation>
</xs:element>
name="binaries">
xs:complexType>
<xs:simpleContent>
  <xs:extension base="xs:hexBinary">
    <xs:attribute name="format" type="xs:string">
      <xs:annotation>
        <xs:documentation>use common values. i.e. "OMA", "NIDEK",
"MO1", "WECO"...</xs:documentation>
      </xs:annotation>
    </xs:attribute>
  </xs:extension>
</xs:simpleContent>
xs:complexType>
</xs:element>
</xs:sequence>
</xs:complexType>
</xs:element>
</xs:choice>
<xs:element name="adjustion" type="xs:float"
minOccurs="0">
  <xs:annotation>
    <xs:documentation>general size
adjustion parameter: Size correction in the Nidek data set.</xs:documentation>
  </xs:annotation>
</xs:element>
</xs:sequence>
</xs:complexType>
</xs:element>
<xs:element name="boxWidth" type="xs:float" minOccurs="0">
  <xs:annotation>
    <xs:documentation>measured box width for size
transformations</xs:documentation>
  </xs:annotation>
</xs:element>
<xs:element name="boxHeight" type="xs:float" minOccurs="0">
  <xs:annotation>
    <xs:documentation>measured box height for size
transformations</xs:documentation>
  </xs:annotation>
</xs:element>
<xs:element name="distanceBetweenLenses" type="xs:float" minOccurs="
0">
  <xs:annotation>
    <xs:documentation>measured dbl for calculation
purposes</xs:documentation>
  </xs:annotation>
</xs:element>
<xs:element name="drillHoles" minOccurs="0" maxOccurs="2">
  <xs:annotation>

```

```

        <xs:documentation>CZ: If attribute side is UNDEFINED
and drillHoles occurs only once the drillhole values are mirrored from right to left side
</xs:documentation>
        </xs:annotation>
        <xs:complexType>
            <xs:complexContent>
                <xs:extension base="DrillHoles">
                    <xs:attribute name="side" type="Sides"
use="prohibited"/>
                </xs:extension>
            </xs:complexContent>
        </xs:complexType>
    </xs:element>
    <xs:element name="pantoscopicAngle" minOccurs="0">
        <xs:complexType>
            <xs:simpleContent>
                <xs:extension base="xs:float">
                    <xs:attribute name="dimension" type="
AngleDimension" use="optional" default="DEG"/>
                </xs:extension>
            </xs:simpleContent>
        </xs:complexType>
    </xs:element>
    <xs:element name="frameBowAngle" minOccurs="0">
        <xs:annotation>
            <xs:documentation>CZ: currently ignored</
xs:documentation>
        </xs:annotation>
        <xs:complexType>
            <xs:simpleContent>
                <xs:extension base="xs:float">
                    <xs:attribute name="dimension" type="
AngleDimension" use="optional" default="DEG"/>
                </xs:extension>
            </xs:simpleContent>
        </xs:complexType>
    </xs:element>
    <xs:element name="remark" type="xs:string" minOccurs="0">
        <xs:annotation>
            <xs:documentation>CZ: Any comments or remarks are
effectively ignored!</xs:documentation>
        </xs:annotation>
    </xs:element>
    <xs:element name="frameCurve" type="xs:float" minOccurs="0">
        <xs:annotation>
            <xs:documentation>CZ: currently ignored</
xs:documentation>
        </xs:annotation>
    </xs:element>
    <xs:sequence>
        <xs:attribute name="quantity" type="xs:integer" use="required"/>
    </xs:complexType>
    <xs:complexType name="TrialFrame">
        <xs:sequence>
            <xs:element name="sphere" minOccurs="0">
                <xs:simpleType>
                    <xs:restriction base="xs:float">
                        <xs:minInclusive value="-50"/>
                        <xs:maxInclusive value="50"/>
                    </xs:restriction>
                </xs:simpleType>
            </xs:element>
            <xs:element name="cylinder" type="Cylinder" minOccurs="0"/>
            <xs:element name="prism" type="Prism" maxOccurs="2"/>
            <xs:element name="decentration">
                <xs:complexType>
                    <xs:sequence>
                        <xs:element name="horizontal" type="xs:float"
"/>
                            <xs:element name="vertical" type="xs:float"/>
                    </xs:sequence>
                </xs:complexType>
            </xs:element>
            <xs:element name="back-vertex-distance" type="xs:float"/>
        </xs:sequence>

```

```

</xs:complexType>
<xs:complexType name="Prism">
  <xs:sequence>
    <xs:element name="power" type="xs:float" />
    <xs:element name="base">
      <xs:simpleType>
        <xs:restriction base="xs:float">
          <xs:minInclusive value="0.0" />
          <xs:maxInclusive value="360.0" />
        </xs:restriction>
      </xs:simpleType>
    </xs:element>
  </xs:sequence>
</xs:complexType>
<xs:complexType name="Cylinder">
  <xs:sequence>
    <xs:element name="power" type="xs:float" />
    <xs:element name="base">
      <xs:simpleType>
        <xs:restriction base="xs:float">
          <xs:minInclusive value="0.0" />
          <xs:maxInclusive value="360.0" />
        </xs:restriction>
      </xs:simpleType>
    </xs:element>
  </xs:sequence>
</xs:complexType>
<xs:complexType name="DrillHoles">
  <xs:choice>
    <xs:element name="pDrillHole" maxOccurs="4">
      <xs:annotation>
        <xs:documentation>CZ: currently ignored - use
cDrillHole instead</xs:documentation>
      </xs:annotation>
      <xs:complexType>
        <xs:sequence>
          <xs:element name="point" maxOccurs="2">
            <xs:complexType>
              <xs:sequence>
                <xs:element name="angle"
" >
                </xs:sequence>
              </xs:complexType>
            </xs:element>
          </xs:sequence>
        </xs:complexType>
      </xs:element>
    </xs:choice>
  </xs:complexType>
  <xs:extension base="xs:float" />
  <xs:simpleContent>
    </xs:element>
  </xs:complexType>
  <xs:element name="radius" type="xs:float">
    <xs:annotation>
      <xs:documentation>mm</xs:documentation>
    </xs:annotation>
  </xs:element>
  <xs:element name="z"
type="xs:float" minOccurs="0">
    <xs:annotation>
      <xs:documentation>mm</xs:documentation>
    </xs:annotation>
  </xs:element>
</xs:sequence>
</xs:complexType>
<xs:element name="cDrillHole" maxOccurs="4">

```



```

        </xs:annotation>
    </xs:element>
    <xs:element name="
interpupillaryDistance" type="xs:float" minOccurs="0">
        <xs:annotation>
            <
xs:documentation>CZ: currently ignored</xs:documentation>
        </xs:annotation>
    </xs:element>
    <xs:element name="
nearObjectDistance" type="xs:float" minOccurs="0"/>
        </xs:sequence>
        </xs:extension>
        </xs:complexContent>
        </xs:complexType>
    </xs:element>
    <xs:element name="lens" maxOccurs="2">
        <xs:complexType>
            <xs:complexContent>
                <xs:extension base="Lens">
                    <xs:attribute name="quantity" type="
xs:integer" use="required">
                        <xs:annotation>
                            <xs:documentation>CZ:
any quantity other than 1 will result in an exception thrown to the client! YOU HAVE BEEN
WARNED!</xs:documentation>
                        </xs:annotation>
                    </xs:attribute>
                </xs:extension>
            </xs:complexContent>
        </xs:complexType>
    </xs:element>
    <xs:element name="frame" type="Frame" minOccurs="0"/>
    <xs:element name="edging" minOccurs="0">
        <xs:complexType>
            <xs:sequence>
                <xs:element name="bevel">
                    <xs:complexType>
                        <xs:complexContent>
                            <xs:extension base="
Bevel"/>
                                </xs:complexContent>
                            </xs:complexType>
                        </xs:element>
                        <xs:element name="polish" type="xs:boolean"/>
                        <xs:element name="chamfer" type="xs:integer">
                            <xs:annotation>
                                <xs:documentation>Bitmap:
0=no, 1=front, 2=back, 4=strong, : currently ignored</xs:documentation>
                            </xs:annotation>
                        </xs:element>
                        <xs:element name="ignoreFlags" type="
xs:string" minOccurs="0" maxOccurs="unbounded">
                            <xs:annotation>
                                <xs:documentation>CZ:
currently ignored</xs:documentation>
                            </xs:annotation>
                        </xs:element>
                    </xs:sequence>
                    <xs:attribute name="edgingType" type="EdgingType" use
="required"/>
                </xs:complexType>
            </xs:element>
            <xs:element name="remark" type="xs:string" minOccurs="0">
                <xs:annotation>
                    <xs:documentation>CZ: Any comments or remarks are
effectively ignored!</xs:documentation>
                </xs:annotation>
            </xs:element>
        </xs:sequence>
        <xs:attribute name="thicknessMatching" type="xs:integer" use="optional">
            <xs:annotation>
                <xs:documentation>0=UNDEF, 1=MID, 2=EDGE</xs:documentation>
                <xs:documentation>CZ: value 2 currently ignored</
xs:documentation>
    </xs:documentation>

```



```

        </xs:annotation>
    </xs:attribute>
    <xs:attribute name="weightMatching" type="xs:boolean" use="optional">
        <xs:annotation>
            <xs:documentation>CZ: currently ignored</xs:documentation>
        </xs:annotation>
    </xs:attribute>
    <xs:attribute name="prismMatching" type="xs:boolean" use="optional">
        <xs:annotation>
            <xs:documentation>CZ: currently ignored</xs:documentation>
        </xs:annotation>
    </xs:attribute>
    <xs:attribute name="baseMatching" type="xs:boolean" use="optional">
        <xs:annotation>
            <xs:documentation>CZ: currently ignored</xs:documentation>
        </xs:annotation>
    </xs:attribute>
</xs:complexType>
<xs:complexType name="GeometryType">
    <xs:sequence>
        <xs:element name="diameter">
            <xs:complexType>
                <xs:sequence>
                    <xs:element name="physical">
                        <xs:annotation>
                            <xs:documentation>
Physikalischer Durchmesser</xs:documentation>
                        </xs:annotation>
                    <xs:simpleType>
                        <xs:restriction base="
xs:integer">
                            <xs:minInclusive value
="1"/>
                            <xs:maxInclusive value
="99"/>
                        </xs:restriction>
                    </xs:simpleType>
                </xs:element>
                <xs:element name="optical" minOccurs="0">
                    <xs:annotation>
                        <xs:documentation>Optisch
wirksamer Durchmesser - nur vorhanden, falls unterschiedlich vom physikalischen
Durchmesser (also bei vordezentrierten Glaesern): currently ignored</xs:documentation>
                    </xs:annotation>
                    <xs:simpleType>
                        <xs:restriction base="
xs:integer">
                            <xs:minInclusive value
="1"/>
                            <xs:maxInclusive value
="99"/>
                        </xs:restriction>
                    </xs:simpleType>
                </xs:element>
                <xs:element name="encoded" type="xs:string"
minOccurs="0">
                    <xs:annotation>
                        <xs:documentation>i.e. for
Essilor's "commercial diameter": currently ignored</xs:documentation>
                    </xs:annotation>
                </xs:element>
            </xs:sequence>
        </xs:complexType>
    </xs:element>
    <xs:element name="decentration" minOccurs="0">
        <xs:complexType>
            <xs:choice>
                <xs:sequence>
                    <xs:element name="length">
                        <xs:simpleType>
                            <xs:restriction base="
xs:float">
                                <
xs:minInclusive value="0.1"/>
                            <

```

```

xs:maxInclusive value="40.0"/>
</xs:restriction>
</xs:simpleType>
</xs:element>
<xs:element name="direction">
  <xs:simpleType>
    <xs:restriction base="
xs:float">
      <
xs:minInclusive value="0.0"/>
      <
xs:maxInclusive value="360.0"/>
    </xs:restriction>
  </xs:simpleType>
</xs:element>
</xs:sequence>
<xs:sequence>
  <xs:annotation>
    <xs:documentation>CZ:
currently ignored - use length - direction instead!</xs:documentation>
  </xs:annotation>
  <xs:element name="horizontal" type="
xs:float"/>
  <xs:element name="vertical" type="
xs:float"/>
</xs:sequence>
</xs:choice>
<xs:attribute name="origin" use="optional" default="
internal">
  <xs:simpleType>
    <xs:restriction base="xs:string">
      <xs:enumeration value="
internal"/>
      <xs:enumeration value="
customer"/>
    </xs:restriction>
  </xs:simpleType>
</xs:attribute>
</xs:complexType>
</xs:element>
<xs:element name="thickness" minOccurs="0">
  <xs:annotation>
    <xs:documentation>this means "minimum thickness". The
real thickness can even be larger.: minimum center thickness</xs:documentation>
  </xs:annotation>
  <xs:complexType>
    <xs:simpleContent>
      <xs:extension base="xs:float">
        <xs:attribute name="reference" type="
ThicknessReferences" use="required"/>
      </xs:extension>
    </xs:simpleContent>
  </xs:complexType>
</xs:element>
<xs:element name="thicknessReduction" type="xs:boolean" minOccurs="0"
">
  <xs:annotation>
    <xs:documentation>CZ: Flag for our Optima</
xs:documentation>
  </xs:annotation>
</xs:element>
<xs:element name="curve" type="Curve" minOccurs="0"/>
<xs:element name="inset" type="xs:float" minOccurs="0">
  <xs:annotation>
    <xs:documentation>for lenses with variable insets:
currently ignored</xs:documentation>
  </xs:annotation>
</xs:element>
<xs:element name="upset" type="xs:float" minOccurs="0">
  <xs:annotation>
    <xs:documentation>for lenses with variable upsets:
currently ignored</xs:documentation>
  </xs:annotation>
</xs:element>
<xs:element name="progressionLength" type="xs:float" minOccurs="0">

```

```
        <xs:annotation>
          <xs:documentation>for progressive lenses with
variable length of progressionzone: currently ignored</xs:documentation>
        </xs:annotation>
      </xs:element>
    </xs:sequence>
  </xs:complexType>
</xs:schema>
```

3.2 Änderungen von Version 1.2.3 nach 1.5.0

Folgende Änderungen wurden durchgeführt:

Entfernte Typen:

simpleType Currencies wurde entfernt.

Begründung: Currencies wurde nirgends verwendet

simpleType DeliveryMethods wurde entfernt.

Begründung: Dieser Type war ein freier Text ohne Vorgaben oder Restriktionen. Eignet sich nicht für eine Weiterverarbeitung.

complexType CurrencyValue wurde entfernt.

Begründung: Currencies wurde nirgends verwendet

complexType TrialFrame wurde entfernt.

Begründung: War ungenügend definiert und wurde von keinem verwendet. Wird später in einer korrekte Fassung definiert, wenn es benötigt wird.

Zugefügte Typen:

simpleType Gender wurde zugefügt

simpleType TracerBinaryFormat wurde zugefügt

simpleType TracerType wurde zugefügt

complexType Coating wurde zugefügt

complexType Decentration wurde zugefügt

complexType Diameter wurde zugefügt

complexType Edging wurde zugefügt

complexType IProfilerData wurde zugefügt

complexType IProfilerMap wurde zugefügt

complexType IProfilerResult wurde zugefügt

complexType Patient wurde zugefügt

complexType RXDataTypeSimple wurde zugefügt

complexType TracerData wurde zugefügt

complexType Zernikes wurde zugefügt

complexType Zernikes7 wurde zugefügt

complexType Zernikes8 wurde zugefügt

complexType Zernikes9 wurde zugefügt

complexType Zernikes10 wurde zugefügt

complexType Zernikes11 wurde zugefügt

complexType Zernikes12 wurde zugefügt

Geänderte Typen:

complexType Address wurde geändert.

Elemente province, region und state wurden entfernt.

Elemente city zip und countryCode sind nicht mehr zwingend erforderlich.

complexType Cylinder wurde geändert.

Elemente base wurde nach axis umbenannt.

complexType DrillHoles wurde geändert.

Struktur zum Element point wurde in den neu definierte complexType CPoint bzw. PPoint ausgelagert.

Element depth wurde zugefügt.

Element diameterHole wurde zugefügt

complexType Frame wurde geändert.

Struktur zum Element tracerData wurde in den neu definierte complexType TracerData ausgelagert.

Element adjustment wurde in den complexType TracerData verlagert.

Zum Element explicit wurde das Attribut side definiert.

complexType GeometryType wurde geändert.

Struktur zum Element diameter wurde in den neu definierte complexType Diameter ausgelagert.

Element elliptic wurde zum complexType Diameter zugefügt.

Wichtig: Im complexType Diameter wird bei einem vordezentrierten Glas der kleinere Durchmesser

immer im Element physical abgelegt. Der größere Durchmesser wird im Element optical angegeben.

Struktur zum Element decentration wurde in den neu definierte complexType Decentration ausgelagert.

Element waveFrontOptimisation wurde hinzugefügt

Element designType wurde hinzugefügt

Element progressionFarVisionShiftDistance wurde hinzugefügt

Element progressionNearVisionShiftDistance wurde hinzugefügt

Element progressionZoneCalculationType wurde hinzugefügt

complexType Header wurde geändert.

Element cultureId wurde entfernt

complexType Item wurde geändert.

Element deliveryMethod wurde entfernt

Element semi wurde entfernt

complexType Lens wurde geändert.

Element remakeType wurde entfernt
Element originalOrderId wurde entfernt
Element reason wurde entfernt
Struktur zum Element coating wurde in den neu definierte complexType Coating ausgelagert.
Element lenticular wurde entfernt
Element aniseicony wurde entfernt
Element toric wurde entfernt
Das Attribut value wurde im Element slaboff entfernt

complexType Pair wurde geändert.

Struktur zum Element patient wurde in den neu definierte complexType Patient ausgelagert.
Struktur zum Element edging wurde in den neu definierte complexType Edging ausgelagert.
Element classification wurde entfernt.
Element Gender wurde dem complexType Patient zugefügt
Element iProfilerData wurde dem complexType Patient zugefügt
Element nearRefractionDistance wurde dem complexType Patient zugefügt
Element nearRefractionDistance wurde dem complexType Patient zugefügt
Attribut thicknessMatching ist nun vom Type boolean statt vom Type integer.

complexType ProductCatalog wurde geändert.

Element version wurde entfernt
Enumeration zum Element name wurde zugefügt.

complexType RXDataType wurde geändert.

Element trialFrame wurde entfernt.

complexType StockLens wurde geändert.

Struktur zum Element coating wurde in den neu definierte complexType Coating ausgelagert.
Struktur zum Element diameter wurde in den neu definierte complexType Diameter ausgelagert.

complexType Size wurde umbenannt nach FrameSize.

19.03.2008

simpleType BevelTypes

Der Wert "NORMAL" wurde umbenannt nach "BEVEL"

simpleType ProgressionZoneCalculationType wieder entfernt.

das Element /GeometryType/progressionZoneCalculationType ist nun vom type String.

complexType Item/options/insurance

ist nun vom Type boolean

complexType Decentration/direction

ist nun vom Type integer

simpleType EdgingType

Wert NONE wurde entfernt

complexType Edging

Element drilling wurde zugefügt

complexType Item

Element multiplePair zugefügt.

complexType Lens

Element branding zugefügt.

complexType patient

Element interpupillaryDistance entfernt und interpupillaryDistanceRight bzw. interpupillaryDistanceLeft zugefügt.
Element ipseo zugefügt.

complexType Frame

Element remark wurde entfernt.

complexType Edging / complexType Lens

Element ignoreFlags wurden von Edging nach Lens verschoben

complexType Shape

Element perimeter wurde entfernt.
Attribut dimensions wurde entfernt.

complexType GeometryType

Element thicknessReductionThin wurde zugefügt.
Struktur um die Elemente thickness und thicknessReduction wurde geändert.

simpleType ThicknessReference

Wert FORNYLOR und THIN wurden entfernt.

24.04.2008

simpleType References wurde entfernt.

Attribut Reference im complexType Shape wurde entfernt.

complexType Pair:

Die Attribute thicknessMatching, weightMatching, prismMatching und baseMatching wurden in Elemente umgewandelt.

complexType Coating:

Element colorName zugefügt.

complexType ProductCatalog:

Aufzähungselement "czv" zugefügt

complexType FrameSize

Alle Felder sind nun optional.

simpleType ChamferIntensity zugefügt

simpleType ChamferPos zugefügt

ComplexType Edging

Der Wert vom Element chamfer ist nun vom Type ChamferIntensity
Das Attribut Position vom Type ChamferPos wurde zum Element chamfer zugefügt.
Das Element chamfer ist nun optional.
Das Element drilling ist nun optional.
Das Element polish ist nun optional

SimpleType SidesSimple zugefügt

Im ComplexType Frame wurde für das Element explicit das Attribut Side geändert und ist nun vom Type SidesSimple.

SimpleType BevelTypes

Folgende werte wurden zugefügt

FRAMECURVATURE

FRAMEBASE

ComplexType Frame

Element frameReferenceId zugefügt

31.10.2008

SimpleType AdditionRefractionMethod zugefügt**complexType Patient:**

Element headTilt zugefügt.

Element additionRefractionMethod zugefügt

Element headCape zugefügt

complexType Edging:

Attribut Position im Element chamfer ist nun kleingeschrieben.

complexType DrillHoles:

Maximale Anzahl von 4 auf 10 gesetzt.

complexType Coating

Attribut coatingType ist nur required.

Hinweis zugefügt:

- Verwendet wird mindestens COLOR bei Farben, für alles andere OTHER.
- Werden die Daten doch ausgefüllt legt man bei Mehrschichten folgende Priorität fest: ANTIREFLEX, COLOR, HARD, CLEAN, UV, OTHER .

17.02.2009

complexType Patient:

Element headCape zugefügt

complexType Centration:

Element eyeRotationCenterDistance zugefügt

24.06.2010

simpleType RCDReferences wurde zugefügt

complexType Centration wurde geändert.

Attribut RCDReferences wurde zum Element eyeRotationCenterDistance zugefügt.

complexType GeometryType wurde geändert.

Dem Element progressionLength wurde das Element progressionMiddleVisionShiftDistance zugefügt

complexType Patient wurde geändert.

Das Element middleObjectDistance zugefügt
Das Element farObjectDistance zugefügt

Die Einheit von nearObjectDistance wurde von cm auf mm geändert.

simpleType FittingPlace wurde zugefügt.

complexType Fitting wurde zugefügt.

complexType Pair wurde geändert.

Das Element fitting zugefügt

12.07.2010

simpleType ApplianceWeightUnity wurde zugefügt.

complexType ApplianceWeight wurde zugefügt.

complexType Patient wurde geändert.

Das Element applianceWeight wurde zugefügt

complexType Diameter wurde geändert.

Das Element physicalVertical wurde zugefügt

complexType RxDataTypeFn wurde zugefügt.

complexType Lens wurde geändert.

Das Element rxDataFn wurde zugefügt

12.07.2010

simpleType RxDataReferences wurde zugefügt.

complexType RxDataTypeNearFar wurde zugefügt.

complexType RxDataTypeFn wurde geändert.

Das Attribut references wurde entfernt

complexType Lens wurde geändert.

Das Element rxDataFn ist nun vom Type RxDataTypeFarNear

3.3 Version 1.5.0 Beta

08.05.2008 ACHTUNG! Diese Version ist noch nicht freigegeben

```

<?xml version="1.0" encoding="UTF-8"?>
<xs:schema xmlns:xs="http://www.w3.org/2001/XMLSchema" elementFormDefault="qualified"
attributeFormDefault="unqualified" version="1.5.0">
  <xs:element name="b2bOptic">
    <xs:complexType>
      <xs:sequence>
        <xs:element name="header" type="Header"/>
        <xs:element name="items">
          <xs:complexType>
            <xs:sequence>
              <xs:element name="item" type="Item"
maxOccurs="unbounded"/>
            </xs:sequence>
          </xs:complexType>
        </xs:element>
        <xs:element name="experimental" type="xs:anyType" minOccurs="0"
maxOccurs="unbounded"/>
      </xs:sequence>
    </xs:complexType>
  </xs:element>
  <xs:simpleType name="AngleDimension">
    <xs:restriction base="xs:string">
      <xs:enumeration value="DEG"/>
      <xs:enumeration value="RAD"/>
      <xs:enumeration value="MM"/>
    </xs:restriction>
  </xs:simpleType>
  <xs:simpleType name="BevelPosType">
    <xs:restriction base="xs:string">
      <xs:enumeration value="AUTO"/>
      <xs:enumeration value="FRONT"/>
      <xs:enumeration value="BACK"/>
      <xs:enumeration value="RELATION"/>
      <xs:enumeration value="FRAMECURVATURE"/>
      <xs:enumeration value="FRAMEBASE"/>
    </xs:restriction>
  </xs:simpleType>
  <xs:simpleType name="BevelTypes">
    <xs:restriction base="xs:string">
      <xs:enumeration value="BEVEL"/>
      <xs:enumeration value="FLAT"/>
      <xs:enumeration value="GROOVED"/>
    </xs:restriction>
  </xs:simpleType>
  <xs:simpleType name="ChamferIntensity">
    <xs:restriction base="xs:string">
      <xs:enumeration value="THIN"/>
      <xs:enumeration value="MEDIUM"/>
      <xs:enumeration value="LARGE"/>
    </xs:restriction>
  </xs:simpleType>
  <xs:simpleType name="ChamferPos">
    <xs:restriction base="xs:string">
      <xs:enumeration value="BOTH"/>
      <xs:enumeration value="FRONT"/>
      <xs:enumeration value="BACK"/>
    </xs:restriction>
  </xs:simpleType>
  <xs:simpleType name="CoatingTypes">
    <xs:restriction base="xs:string">

```

```

        <xs:enumeration value="COLOR"/>
        <xs:enumeration value="UV"/>
        <xs:enumeration value="ANTIREFLEX"/>
        <xs:enumeration value="HARD"/>
        <xs:enumeration value="CLEAN"/>
        <xs:enumeration value="OTHER"/>
    </xs:restriction>
</xs:simpleType>
<xs:simpleType name="EdgingType">
    <xs:restriction base="xs:string">
        <xs:enumeration value="ROUGHING"/>
        <xs:enumeration value="ONSHAPE"/>
        <xs:enumeration value="GIVENFRAME"/>
        <xs:enumeration value="ORDEREDFRAME"/>
    </xs:restriction>
</xs:simpleType>
<xs:simpleType name="FrameMaterials">
    <xs:restriction base="xs:string">
        <xs:enumeration value="METAL"/>
        <xs:enumeration value="PLASTIC"/>
        <xs:enumeration value="OPTYL"/>
        <xs:enumeration value="NYLOR"/>
        <xs:enumeration value="DRILLED"/>
        <xs:enumeration value="SPECIAL"/>
    </xs:restriction>
</xs:simpleType>
<xs:simpleType name="Gender">
    <xs:restriction base="xs:string">
        <xs:enumeration value="MALE"/>
        <xs:enumeration value="FEMALE"/>
    </xs:restriction>
</xs:simpleType>
<xs:simpleType name="HeightReferences">
    <xs:restriction base="xs:string">
        <xs:enumeration value="OVERBOX"/>
        <xs:enumeration value="OVERSHAPE"/>
    </xs:restriction>
</xs:simpleType>
<xs:simpleType name="MsgStates">
    <xs:restriction base="xs:string">
        <xs:enumeration value="NEW"/>
        <xs:enumeration value="UPDATE"/>
        <xs:enumeration value="CANCEL"/>
    </xs:restriction>
</xs:simpleType>
<xs:simpleType name="MsgSteps">
    <xs:restriction base="xs:string">
        <xs:enumeration value="CREATE"/>
        <xs:enumeration value="TRANSFER"/>
        <xs:enumeration value="RECEIPT"/>
    </xs:restriction>
</xs:simpleType>
<xs:simpleType name="MsgTypes">
    <xs:restriction base="xs:string">
        <xs:enumeration value="ORDER"/>
        <xs:enumeration value="REQUEST"/>
        <xs:enumeration value="CALCULATION"/>
        <xs:enumeration value="VALIDATION"/>
    </xs:restriction>
</xs:simpleType>
<xs:simpleType name="OCReferences">
    <xs:restriction base="xs:string">
        <xs:enumeration value="FAR"/>
        <xs:enumeration value="NEAR"/>
    </xs:restriction>
</xs:simpleType>
<xs:simpleType name="Roles">
    <xs:restriction base="xs:string">
        <xs:enumeration value="ORIGINATOR"/>
        <xs:enumeration value="SUPPLIER"/>
        <xs:enumeration value="SHIPTO"/>
    </xs:restriction>

```

```
        <xs:enumeration value="CARRIER"/>
        <xs:enumeration value="INVOICETO"/>
        <xs:enumeration value="PAIDBY"/>
        <xs:enumeration value="MANUFACTURER"/>
    </xs:restriction>
</xs:simpleType>
<xs:simpleType name="Sides">
    <xs:restriction base="xs:string">
        <xs:enumeration value="RIGHT"/>
        <xs:enumeration value="LEFT"/>
        <xs:enumeration value="UNDEFINED"/>
    </xs:restriction>
</xs:simpleType>
<xs:simpleType name="SidesSimple">
    <xs:restriction base="xs:string">
        <xs:enumeration value="RIGHT"/>
        <xs:enumeration value="LEFT"/>
    </xs:restriction>
</xs:simpleType>
<xs:simpleType name="SoftwareTypes">
    <xs:restriction base="xs:string">
        <xs:enumeration value="ORIGINATOR"/>
        <xs:enumeration value="VERIFIER"/>
        <xs:enumeration value="SENDER"/>
    </xs:restriction>
</xs:simpleType>
<xs:simpleType name="ThicknessReferences">
    <xs:restriction base="xs:string">
        <xs:enumeration value="REDUCEWITHSHAPE"/>
        <xs:enumeration value="CENTER"/>
        <xs:enumeration value="EDGE"/>
        <xs:enumeration value="DRILLHOLE"/>
    </xs:restriction>
</xs:simpleType>
<xs:simpleType name="TracerBinaryFormat">
    <xs:restriction base="xs:string">
        <xs:enumeration value="DLL BRIOT"/>
        <xs:enumeration value="DVI"/>
        <xs:enumeration value="GT3000"/>
        <xs:enumeration value="MO1"/>
        <xs:enumeration value="NIDEK"/>
        <xs:enumeration value="OMA3.02"/>
        <xs:enumeration value="PHI"/>
        <xs:enumeration value="T4"/>
        <xs:enumeration value="WECO"/>
    </xs:restriction>
</xs:simpleType>
<xs:simpleType name="TracerType">
    <xs:restriction base="xs:string">
        <xs:enumeration value="Hoya 3DFT"/>
        <xs:enumeration value="Hoya GT1000"/>
        <xs:enumeration value="Hoya GT3000"/>
        <xs:enumeration value="Hoya GT3000 OMA"/>
        <xs:enumeration value="Hoya UT1000"/>
        <xs:enumeration value="Essilor Gamma"/>
        <xs:enumeration value="Essilor PHI PCCOM"/>
        <xs:enumeration value="Essilor PHI OMA"/>
        <xs:enumeration value="Essilor Kappa PCCOM"/>
        <xs:enumeration value="Essilor Kappa OMA"/>
        <xs:enumeration value="National Optronics 4T"/>
        <xs:enumeration value="Briot ScanfomNet I"/>
        <xs:enumeration value="Briot ScanfomNet II"/>
        <xs:enumeration value="Weco 3DFT+"/>
        <xs:enumeration value="Weco Trace II"/>
        <xs:enumeration value="Weco Trace III"/>
        <xs:enumeration value="Nidek LT700"/>
        <xs:enumeration value="Nidek LT900"/>
        <xs:enumeration value="Nidek LT900 OMA"/>
        <xs:enumeration value="Nidek LT1000"/>
        <xs:enumeration value="Indo NDK"/>
        <xs:enumeration value="Indo OMA"/>
    </xs:restriction>
</xs:simpleType>
```

```

        <xs:enumeration value="Topcon FR50"/>
        <xs:enumeration value="Takubomatic FD80"/>
        <xs:enumeration value="Unknown"/>
    </xs:restriction>
</xs:simpleType>
<xs:complexType name="Account">
    <xs:sequence>
        <xs:element name="id">
            <xs:complexType>
                <xs:simpleContent>
                    <xs:extension base="xs:string">
                        <xs:attribute name="memberShipID"
type="xs:long" use="optional" default="1"/>
                    </xs:extension>
                </xs:simpleContent>
            </xs:complexType>
        </xs:element>
        <xs:element name="name" type="xs:string" minOccurs="0"/>
        <xs:element name="address" type="Address" minOccurs="0"/>
        <xs:element name="contact" type="ContactInfo" minOccurs="0"/>
    </xs:sequence>
</xs:complexType>
<xs:complexType name="Address">
    <xs:sequence>
        <xs:element name="addressLine" type="xs:string" minOccurs="0" maxOccurs="3"/>
        <xs:element name="poBox" type="xs:string" minOccurs="0"/>
        <xs:element name="city" type="xs:string" minOccurs="0"/>
        <xs:element name="zip" type="xs:string" minOccurs="0"/>
        <xs:element name="countryCode" type="xs:string" minOccurs="0"/>
    </xs:sequence>
</xs:complexType>
<xs:complexType name="Bevel">
    <xs:sequence>
        <xs:element name="type" type="BevelTypes"/>
        <xs:element name="position" minOccurs="0" maxOccurs="2">
            <xs:complexType>
                <xs:simpleContent>
                    <xs:extension base="xs:float">
                        <xs:attribute name="posType"
type="BevelPosType" use="optional" default="AUTO"/>
                    </xs:extension>
                </xs:simpleContent>
            </xs:complexType>
        </xs:element>
        <xs:element name="grooveDepth" type="xs:float" minOccurs="0"/>
        <xs:element name="grooveWidth" type="xs:float" minOccurs="0"/>
    </xs:sequence>
</xs:complexType>
<xs:complexType name="Centration">
    <xs:sequence>
        <xs:element name="monocularCentrationDistance">
            <xs:complexType>
                <xs:simpleContent>
                    <xs:extension base="xs:float">
                        <xs:attribute name="reference"
type="OCReferences" use="required"/>
                    </xs:extension>
                </xs:simpleContent>
            </xs:complexType>
        </xs:element>
        <xs:element name="height">
            <xs:complexType>
                <xs:simpleContent>
                    <xs:extension base="xs:float">
                        <xs:attribute name="reference"
type="OCReferences" use="required"/>
                        <xs:attribute name="referenceHeight"
type="HeightReferences" use="required"/>
                    </xs:extension>
                </xs:simpleContent>
            </xs:complexType>
        </xs:element>
    </xs:sequence>
</xs:complexType>

```

```

        </xs:simpleContent>
      </xs:complexType>
    </xs:element>
    <xs:element name="backVertexDistance" type="xs:float" minOccurs="0"/>
  </xs:sequence>
</xs:complexType>
<xs:complexType name="Coating">
  <xs:sequence>
    <xs:element name="commercialCode" type="xs:string"/>
    <xs:element name="minIntensity" type="xs:integer" minOccurs="0"/>
    <xs:element name="maxIntensity" type="xs:integer" minOccurs="0"/>
    <xs:element name="colorName" type="xs:string" minOccurs="0"/>
  </xs:sequence>
  <xs:attribute name="coatingType" type="CoatingTypes" use="optional"/>
</xs:complexType>
<xs:complexType name="ContactInfo">
  <xs:sequence>
    <xs:element name="title" type="xs:string" minOccurs="0"/>
    <xs:element name="firstName" type="xs:string" minOccurs="0"/>
    <xs:element name="lastName" type="xs:string"/>
    <xs:element name="phone" type="xs:string" minOccurs="0" maxOccurs="unbounded"/>
    <xs:element name="fax" type="xs:string" minOccurs="0" maxOccurs="unbounded"/>
    <xs:element name="eMail" type="xs:string" minOccurs="0" maxOccurs="unbounded"/>
  </xs:sequence>
</xs:complexType>
<xs:complexType name="CPoint">
  <xs:sequence>
    <xs:element name="x" type="xs:float"/>
    <xs:element name="y" type="xs:float"/>
    <xs:element name="z" type="xs:float" minOccurs="0"/>
  </xs:sequence>
</xs:complexType>
<xs:complexType name="Curve">
  <xs:choice>
    <xs:element name="flat" type="xs:boolean"/>
    <xs:element name="moreCurved" type="xs:boolean"/>
    <xs:element name="baseCurve" type="xs:float"/>
    <xs:element name="planoConcave" type="xs:boolean"/>
    <xs:element name="planoConvex" type="xs:boolean"/>
    <xs:element name="biConcave" type="xs:boolean"/>
    <xs:element name="biConvex" type="xs:boolean"/>
  </xs:choice>
</xs:complexType>
<xs:complexType name="Cylinder">
  <xs:sequence>
    <xs:element name="power" type="xs:float"/>
    <xs:element name="axis">
      <xs:simpleType>
        <xs:restriction base="xs:float">
          <xs:minInclusive value="0.0"/>
          <xs:maxInclusive value="360.0"/>
        </xs:restriction>
      </xs:simpleType>
    </xs:element>
  </xs:sequence>
</xs:complexType>
<xs:complexType name="Decentration">
  <xs:choice>
    <xs:sequence>
      <xs:element name="length" type="xs:float"/>
      <xs:element name="direction" type="xs:integer"/>
    </xs:sequence>
    <xs:sequence>
      <xs:element name="horizontal" type="xs:float"/>
      <xs:element name="vertical" type="xs:float"/>
    </xs:sequence>
    <xs:sequence>
      <xs:element name="hdec" type="xs:float"/>
    </xs:sequence>
  </xs:choice>
</xs:complexType>

```

```

<xs:complexType name="Diameter">
  <xs:sequence>
    <xs:element name="physical" type="xs:integer"/>
    <xs:element name="optical" type="xs:integer" minOccurs="0"/>
    <xs:element name="elliptic" type="xs:boolean" default="false" minOccurs="0"/>
    <xs:element name="encoded" type="xs:string" minOccurs="0"/>
  </xs:sequence>
</xs:complexType>
<xs:complexType name="DrillHoles">
  <xs:choice>
    <xs:element name="pDrillHole" maxOccurs="4">
      <xs:complexType>
        <xs:sequence>
          <xs:element name="point" type="PPoint" maxOccurs="2"/>
          <xs:element name="depth" type="xs:float" minOccurs="0"/>
          <xs:element name="diameterHole" type="xs:float"
minOccurs="0"/>
        </xs:sequence>
      </xs:complexType>
    </xs:element>
    <xs:element name="cDrillHole" maxOccurs="4">
      <xs:complexType>
        <xs:sequence>
          <xs:element name="point" type="CPoint" maxOccurs="2"/>
          <xs:element name="depth" type="xs:float" minOccurs="0"/>
          <xs:element name="diameterHole" type="xs:float"
minOccurs="0"/>
        </xs:sequence>
      </xs:complexType>
    </xs:element>
  </xs:choice>
</xs:complexType>
<xs:complexType name="Edging">
  <xs:sequence>
    <xs:element name="bevel" type="Bevel"/>
    <xs:element name="polish" type="xs:boolean" default="false" minOccurs="0"/>
    <xs:element name="drilling" type="xs:boolean" default="false" minOccurs="0"/>
    <xs:element name="chamfer" minOccurs="0">
      <xs:complexType>
        <xs:simpleContent>
          <xs:extension base="ChamferIntensity">
            <xs:attribute name="Position" type="ChamferPos"
use="optional" default="BOTH"/>
          </xs:extension>
        </xs:simpleContent>
      </xs:complexType>
    </xs:element>
  </xs:sequence>
  <xs:attribute name="edgingType" type="EdgingType" use="required"/>
</xs:complexType>
<xs:complexType name="Frame">
  <xs:sequence>
    <xs:element name="material" type="FrameMaterials"/>
    <xs:element name="manufacturer" type="xs:string" minOccurs="0"/>
    <xs:element name="brand" type="xs:string" minOccurs="0"/>
    <xs:element name="model" type="xs:string" minOccurs="0"/>
    <xs:element name="size" type="FrameSize" minOccurs="0"/>
    <xs:element name="color" type="xs:string" minOccurs="0"/>
    <xs:element name="commercialCode" type="xs:string" minOccurs="0"/>
    <xs:element name="shape" minOccurs="0">
      <xs:complexType>
        <xs:sequence>
          <xs:choice>
            <xs:element name="catalog">
              <xs:complexType>
                <xs:sequence>
                  <xs:element
name="shapeld" type="xs:string"/>
                </xs:sequence>
              </xs:complexType>
            </xs:choice>
          </xs:sequence>
        </xs:complexType>
      </xs:element>
    </xs:element>
  </xs:sequence>
</xs:complexType>

```



```

        <xs:element name="explicit" maxOccurs="2">
            <xs:complexType>
                <xs:complexContent>
                    <xs:extension
base="Shape"/>
                        </xs:complexContent>
                    </xs:complexType>
                </xs:element>
            </xs:element name="tracerData">
                </xs:choice>
            </xs:sequence>
        </xs:complexType>
    </xs:element>
    <xs:element name="boxWidth" type="xs:float" minOccurs="0"/>
    <xs:element name="boxHeight" type="xs:float" minOccurs="0"/>
    <xs:element name="distanceBetweenLenses" type="xs:float" minOccurs="0"/>
    <xs:element name="drillHoles" minOccurs="0" maxOccurs="2">
        <xs:complexType>
            <xs:complexContent>
                <xs:extension base="DrillHoles">
                    <xs:attribute name="side" type="Sides"
use="required"/>
                </xs:extension>
            </xs:complexContent>
        </xs:complexType>
    </xs:element>
    <xs:element name="pantoscopicAngle" minOccurs="0">
        <xs:complexType>
            <xs:simpleContent>
                <xs:extension base="xs:float">
                    <xs:attribute name="dimension"
type="AngleDimension" use="optional" default="DEG"/>
                </xs:extension>
            </xs:simpleContent>
        </xs:complexType>
    </xs:element>
    <xs:element name="frameBowAngle" minOccurs="0">
        <xs:complexType>
            <xs:simpleContent>
                <xs:extension base="xs:float">
                    <xs:attribute name="dimension"
type="AngleDimension" use="optional" default="DEG"/>
                </xs:extension>
            </xs:simpleContent>
        </xs:complexType>
    </xs:element>
    <xs:element name="frameCurve" type="xs:float" minOccurs="0"/>
    <xs:element name="frameReferenceId" type="xs:string" minOccurs="0"/>
    </xs:sequence>
    <xs:attribute name="quantity" type="xs:integer" use="required"/>
</xs:complexType>
<xs:complexType name="FrameSize">
    <xs:sequence>
        <xs:element name="width" type="xs:float" minOccurs="0"/>
        <xs:element name="height" type="xs:float" minOccurs="0"/>
        <xs:element name="bridge" type="xs:float" minOccurs="0"/>
        <xs:element name="templeLength" type="xs:float" minOccurs="0"/>
    </xs:sequence>
</xs:complexType>
<xs:complexType name="GeometryType">
    <xs:sequence>
        <xs:element name="diameter" type="Diameter"/>
        <xs:element name="decentration" type="Decentration" minOccurs="0"/>
        <xs:element name="waveFrontOptimisation" type="xs:boolean" default="false"
minOccurs="0"/>
    </xs:choice>
        <xs:sequence>
            <xs:element name="thickness" minOccurs="0"
maxOccurs="unbounded"/>
        </xs:sequence>
    </xs:complexType>

```

```

        <xs:simpleContent>
          <xs:extension base="xs:float">
            <xs:attribute name="reference"
type="ThicknessReferences" use="required"/>
          </xs:extension>
        </xs:simpleContent>
      </xs:complexType>
    </xs:element>
    <xs:element name="thicknessReduction" type="xs:boolean"
default="false" minOccurs="0"/>
  </xs:sequence>
  <xs:element name="thicknessReductionThin" type="xs:boolean" default="false"
minOccurs="0"/>
</xs:choice>
<xs:element name="curve" type="Curve" minOccurs="0"/>
<xs:element name="inset" type="xs:float" minOccurs="0"/>
<xs:element name="upset" type="xs:float" minOccurs="0"/>
<xs:element name="designType" minOccurs="0">
  <xs:simpleType>
    <xs:restriction base="xs:string">
      <xs:enumeration value="A"/>
      <xs:enumeration value="B"/>
      <xs:enumeration value="C"/>
    </xs:restriction>
  </xs:simpleType>
</xs:element>
<xs:choice minOccurs="0">
  <xs:element name="progressionLength" type="xs:float"/>
  <xs:sequence>
    <xs:element name="progressionFarVisionShiftDistance"
type="xs:float"/>
    <xs:element name="progressionNearVisionShiftDistance"
type="xs:float"/>
  </xs:sequence>
</xs:choice>
<xs:element name="progressionZoneCalculationType" type="xs:string" minOccurs="0"/>
</xs:sequence>
</xs:complexType>
<xs:complexType name="Header">
  <xs:sequence>
    <xs:element name="customersOrderId" type="xs:string"/>
    <xs:element name="distributorsOrderId" type="xs:string"/>
    <xs:element name="timeStamps" type="TimeStamps" maxOccurs="unbounded"/>
    <xs:element name="remark" type="xs:string" minOccurs="0"/>
    <xs:element name="orderParties" maxOccurs="unbounded">
      <xs:complexType>
        <xs:complexContent>
          <xs:extension base="Account">
            <xs:attribute name="role" type="Roles"
use="required"/>
          </xs:extension>
        </xs:complexContent>
      </xs:complexType>
    </xs:element>
    <xs:element name="software" type="Software" maxOccurs="unbounded"/>
    <xs:element name="productCatalog" type="ProductCatalog" minOccurs="0"/>
    <xs:element name="portalOrderId" type="xs:string"/>
  </xs:sequence>
  <xs:attribute name="msgType" type="MsgTypes" use="optional" default="REQUEST"/>
  <xs:attribute name="msgState" type="MsgStates" use="optional" default="NEW"/>
  <xs:attribute name="testIndicator" type="xs:boolean" use="optional" default="false"/>
</xs:complexType>
<xs:complexType name="IProfilerData">
  <xs:sequence>
    <xs:element name="identification">
      <xs:complexType>
        <xs:sequence>
          <xs:element name="id">
            <xs:simpleType>
              <xs:restriction base="xs:string">
                <xs:minLength value="1"/>
              </xs:restriction>
            </xs:simpleType>
          </xs:element>
        </xs:sequence>
      </xs:complexType>
    </xs:element>
  </xs:sequence>
</xs:complexType>

```

```

        <xs:maxLength value="50"/>
      </xs:restriction>
    </xs:simpleType>
  </xs:element>
  <xs:element name="timeStamp" type="xs:date"/>
  <xs:element name="counter" minOccurs="0">
    <xs:simpleType>
      <xs:restriction base="xs:int">
        <xs:minInclusive value="0"/>
      </xs:restriction>
    </xs:simpleType>
  </xs:element>
  <xs:element name="device" minOccurs="0">
    <xs:complexType>
      <xs:sequence>
        <xs:element name="deviceId">
          <xs:simpleType>
            <xs:restriction base="xs:string">
              <xs:minLength value="1"/>
              <xs:maxLength value="50"/>
            </xs:restriction>
          </xs:simpleType>
        </xs:element>
      </xs:sequence>
    </xs:complexType>
  </xs:element>
  <xs:sequence>
    <xs:element>
      <xs:sequence>
        <xs:complexType>
          <xs:element>
            <xs:sequence>
              <xs:complexType>
                <xs:sequence maxOccurs="unbounded">
                  <xs:element name="point">
                    <xs:complexType>
                      <xs:sequence>
                        <xs:element name="x" type="xs:float"/>
                        <xs:element name="y" type="xs:float"/>
                        <xs:element name="z" type="xs:float"/>
                      </xs:sequence>
                    </xs:complexType>
                  </xs:element>
                </xs:sequence>
              </xs:complexType>
            </xs:element>
          </xs:sequence>
        </xs:complexType>
      </xs:sequence>
    </xs:complexType>
  </xs:sequence>
  <xs:complexType name="IProfilerResult">
    <xs:sequence>
      <xs:element name="autorefractorEye" type="RXDataTypeSimple"/>
      <xs:element name="wavefrontEye">
        <xs:complexType>
          <xs:sequence>
            <xs:element name="pupilCenter" minOccurs="0">
              <xs:complexType>
                <xs:sequence>

```

```

type="xs:float"/>
type="xs:float"/>
minOccurs="0"/>
type="xs:float"/>
type="xs:float"/>
minOccurs="0"/>
use="required"/>
default="false" minOccurs="0"/>
</xs:element name="x">
</xs:element name="y">
</xs:sequence>
</xs:complexType>
</xs:element>
<xs:element name="zernikes" type="Zernikes"/>
<xs:element name="map" type="IProfilerMap"
</xs:sequence>
</xs:complexType>
</xs:element>
<xs:element name="wavefrontCornea" minOccurs="0">
<xs:complexType>
<xs:sequence>
<xs:element name="vertexPosition">
<xs:complexType>
<xs:sequence>
<xs:element name="x">
<xs:element name="y">
</xs:sequence>
</xs:complexType>
</xs:element>
<xs:element name="zernikes" type="Zernikes"/>
<xs:element name="map" type="IProfilerMap"
</xs:sequence>
</xs:complexType>
</xs:element>
</xs:sequence>
<xs:attribute name="side" type="Sides" use="required"/>
</xs:complexType>
<xs:complexType name="Item">
<xs:sequence>
<xs:element name="remark" type="xs:string" minOccurs="0"/>
<xs:element name="parties" minOccurs="0" maxOccurs="unbounded">
<xs:complexType>
<xs:complexContent>
<xs:extension base="Account">
<xs:attribute name="role" type="Roles"
</xs:extension>
</xs:complexContent>
</xs:complexType>
</xs:element>
<xs:element name="referenceNo" type="xs:string"/>
<xs:element name="referenceText" type="xs:string" minOccurs="0"/>
<xs:element name="requestedDate" type="xs:date" minOccurs="0"/>
<xs:element name="manufacturer" type="xs:string"/>
<xs:choice>
<xs:element name="pair" type="Pair"/>
<xs:element name="stockLens" type="StockLens"/>
</xs:choice>
<xs:element name="options" minOccurs="0">
<xs:complexType>
<xs:sequence>
<xs:element name="insurance" type="xs:boolean"
</xs:sequence>
</xs:complexType>
</xs:element>
<xs:element name="multiplePair" minOccurs="0">
<xs:complexType>
<xs:sequence>
<xs:element name="referenceNo" type="xs:string"/>
<xs:element name="referenceCountNo" type="xs:integer"/>
</xs:sequence>
</xs:complexType>

```

```

        </xs:element>
      </xs:sequence>
    </xs:complexType>
  </xs:complexType name="Lens">
    <xs:sequence>
      <xs:element name="commercialCode" type="xs:string"/>
      <xs:element name="ignoreFlags" type="xs:string" minOccurs="0"
maxOccurs="unbounded"/>
      <xs:element name="rxData" type="RXDataType"/>
      <xs:element name="coating" type="Coating" minOccurs="0" maxOccurs="unbounded"/>
      <xs:element name="centration" type="Centration" minOccurs="0"/>
      <xs:element name="geometry" type="GeometryType"/>
      <xs:element name="options" minOccurs="0">
        <xs:complexType>
          <xs:sequence>
            <xs:choice minOccurs="0">
              <xs:element name="occlusion"
type="xs:boolean"/>
              <xs:element name="frosted" type="xs:boolean"/>
            </xs:choice>
            <xs:element name="slabOff" type="xs:boolean"
default="false" minOccurs="0"/>
          </xs:sequence>
        </xs:complexType>
      </xs:element>
      <xs:element name="frameFit" type="xs:float" minOccurs="0"/>
      <xs:element name="engraving" type="xs:string" minOccurs="0"/>
      <xs:element name="branding" type="xs:boolean" default="false" minOccurs="0"/>
      <xs:element name="experimental" type="xs:anyType" minOccurs="0"
maxOccurs="unbounded"/>
    </xs:sequence>
    <xs:attribute name="side" type="Sides" use="required"/>
    <xs:attribute name="balancingLens" type="xs:boolean" use="optional" default="false"/>
    <xs:attribute name="virtualLens" type="xs:boolean" use="optional" default="false"/>
  </xs:complexType>
  <xs:complexType name="Pair">
    <xs:sequence>
      <xs:element name="patient" type="Patient" minOccurs="0"/>
      <xs:element name="lens" maxOccurs="2">
        <xs:complexType>
          <xs:complexContent>
            <xs:extension base="Lens">
              <xs:attribute name="quantity" type="xs:integer"
use="required"/>
            </xs:extension>
          </xs:complexContent>
        </xs:complexType>
      </xs:element>
      <xs:element name="frame" type="Frame" minOccurs="0"/>
      <xs:element name="edging" type="Edging" minOccurs="0"/>
      <xs:element name="remark" type="xs:string" minOccurs="0"/>
      <xs:element name="thicknessMatching" type="xs:boolean" default="false" minOccurs="0"/>
      <xs:element name="weightMatching" type="xs:boolean" default="false" minOccurs="0"/>
      <xs:element name="prismMatching" type="xs:boolean" default="false" minOccurs="0"/>
      <xs:element name="baseMatching" type="xs:boolean" default="false" minOccurs="0"/>
    </xs:sequence>
  </xs:complexType>
  <xs:complexType name="Patient">
    <xs:complexContent>
      <xs:extension base="Account">
        <xs:sequence minOccurs="0">
          <xs:element name="mailAllowed" type="xs:boolean" default="false"
minOccurs="0"/>
          <xs:element name="gender" type="Gender" minOccurs="0"/>
          <xs:element name="dateOfBirth" type="xs:date" minOccurs="0"/>
          <xs:sequence minOccurs="0">
            <xs:element name="interpupillaryDistanceRight"
type="xs:float"/>
            <xs:element name="interpupillaryDistanceLeft"
type="xs:float"/>
          </xs:sequence>
        </xs:sequence>
      </xs:extension>
    </xs:complexContent>
  </xs:complexType>

```

```

minOccurs="0"/>
minOccurs="0"/>
<xs:element name="nearObjectDistance" type="xs:float"
<xs:element name="iProfilerData" type="IProfilerData"
<xs:element name="nearRefractionDistance" minOccurs="0"/>
<xs:element name="ipseo" minOccurs="0">
  <xs:complexType>
    <xs:sequence>
      <xs:element name="he" type="xs:float"/>
      <xs:element name="st" type="xs:float"/>
    </xs:sequence>
  </xs:complexType>
</xs:element>
</xs:sequence>
</xs:extension>
</xs:complexContent>
</xs:complexType>
<xs:complexType name="PPoint">
  <xs:sequence>
    <xs:element name="angle">
      <xs:complexType>
        <xs:simpleContent>
          <xs:extension base="xs:float">
            <xs:attribute name="dimension"
type="AngleDimension" use="optional" default="DEG"/>
          </xs:extension>
        </xs:simpleContent>
      </xs:complexType>
    </xs:element>
    <xs:element name="radius" type="xs:float"/>
    <xs:element name="z" type="xs:float" minOccurs="0"/>
  </xs:sequence>
</xs:complexType>
<xs:complexType name="Prism">
  <xs:sequence>
    <xs:element name="power" type="xs:float"/>
    <xs:element name="base">
      <xs:simpleType>
        <xs:restriction base="xs:float">
          <xs:minInclusive value="0.0"/>
          <xs:maxInclusive value="360.0"/>
        </xs:restriction>
      </xs:simpleType>
    </xs:element>
  </xs:sequence>
</xs:complexType>
<xs:complexType name="ProductCatalog">
  <xs:sequence>
    <xs:element name="name">
      <xs:simpleType>
        <xs:restriction base="xs:string">
          <xs:enumeration value="czv"/>
          <xs:enumeration value="sf4"/>
          <xs:enumeration value="sf6"/>
          <xs:enumeration value="optimeyes"/>
          <xs:enumeration value="euronet"/>
        </xs:restriction>
      </xs:simpleType>
    </xs:element>
    <xs:element name="release" type="xs:string"/>
  </xs:sequence>
</xs:complexType>
<xs:complexType name="RXDataTypeSimple">
  <xs:sequence>
    <xs:element name="sphere" type="xs:float"/>
    <xs:element name="cylinder" type="Cylinder" minOccurs="0"/>
  </xs:sequence>
</xs:complexType>
<xs:complexType name="RXDataType">
  <xs:sequence>
    <xs:element name="sphere">

```

```

        <xs:simpleType>
            <xs:restriction base="xs:float">
                <xs:minInclusive value="-50"/>
                <xs:maxInclusive value="50"/>
            </xs:restriction>
        </xs:simpleType>
    </xs:element>
    <xs:element name="cylinder" type="Cylinder" minOccurs="0"/>
    <xs:element name="addition" minOccurs="0">
        <xs:simpleType>
            <xs:restriction base="xs:float">
                <xs:minInclusive value="0.25"/>
            </xs:restriction>
        </xs:simpleType>
    </xs:element>
    <xs:element name="prism" type="Prism" minOccurs="0" maxOccurs="2"/>
</xs:sequence>
</xs:complexType>
<xs:complexType name="RXDataType4SL">
    <xs:sequence>
        <xs:element name="sphere">
            <xs:simpleType>
                <xs:restriction base="xs:float">
                    <xs:minInclusive value="-50"/>
                    <xs:maxInclusive value="50"/>
                </xs:restriction>
            </xs:simpleType>
        </xs:element>
        <xs:element name="cylinder" type="Cylinder" minOccurs="0"/>
        <xs:element name="addition" minOccurs="0">
            <xs:simpleType>
                <xs:restriction base="xs:float">
                    <xs:minInclusive value="0.25"/>
                </xs:restriction>
            </xs:simpleType>
        </xs:element>
    </xs:sequence>
</xs:complexType>
<xs:complexType name="Shape">
    <xs:sequence>
        <xs:element name="points">
            <xs:complexType>
                <xs:choice>
                    <xs:element name="pPoints" type="PPoint" minOccurs="18"
maxOccurs="unbounded"/>
                    <xs:element name="cPoints" type="CPoint" minOccurs="18"
maxOccurs="unbounded"/>
                </xs:choice>
            </xs:complexType>
        </xs:element>
    </xs:sequence>
</xs:complexType>
<xs:complexType name="Software">
    <xs:sequence>
        <xs:element name="name" type="xs:string"/>
        <xs:element name="version" type="xs:string"/>
    </xs:sequence>
    <xs:attribute name="typeOf" type="SoftwareTypes" use="required"/>
</xs:complexType>
<xs:complexType name="StockLens">
    <xs:sequence>
        <xs:element name="commercialCode" type="xs:string"/>
        <xs:element name="rxData" type="RXDataType4SL"/>
        <xs:element name="coating" type="Coating" minOccurs="0" maxOccurs="unbounded"/>
        <xs:element name="diameter" type="Diameter"/>
    </xs:sequence>
    <xs:attribute name="quantity" type="xs:integer" use="required"/>
    <xs:attribute name="side" type="Sides" use="required"/>
</xs:complexType>
<xs:complexType name="TimeStamps">
    <xs:sequence>

```

```

        <xs:element name="dateTime">
            <xs:complexType>
                <xs:simpleContent>
                    <xs:extension base="xs:dateTime">
                        <xs:attribute name="step" type="MsgSteps"
use="required"/>
                    </xs:extension>
                </xs:simpleContent>
            </xs:complexType>
        </xs:element>
    </xs:sequence>
</xs:complexType>
<xs:complexType name="TracerData">
    <xs:sequence>
        <xs:element name="tracerType" type="TracerType"/>
        <xs:element name="tracerVersion" type="xs:string"/>
        <xs:element name="tracerID" type="xs:string" minOccurs="0"/>
        <xs:element name="binaries">
            <xs:complexType>
                <xs:simpleContent>
                    <xs:extension base="xs:hexBinary">
                        <xs:attribute name="format"
type="TracerBinaryFormat" use="required"/>
                    </xs:extension>
                </xs:simpleContent>
            </xs:complexType>
        </xs:element>
        <xs:element name="adjustion" type="xs:float" minOccurs="0"/>
    </xs:sequence>
</xs:complexType>
<xs:complexType name="Zernikes">
    <xs:choice>
        <xs:element name="zernikes7" type="Zernikes7"/>
        <xs:element name="zernikes8" type="Zernikes8"/>
        <xs:element name="zernikes9" type="Zernikes9"/>
        <xs:element name="zernikes10" type="Zernikes10"/>
        <xs:element name="zernikes11" type="Zernikes11"/>
        <xs:element name="zernikes12" type="Zernikes12"/>
    </xs:choice>
</xs:complexType>
<xs:complexType name="Zernikes7">
    <xs:sequence>
        <xs:element name="pupilDiameter" type="xs:float"/>
        <xs:element name="z_0_0" type="xs:float"/>
        <xs:element name="z_1_M1" type="xs:float"/>
        <xs:element name="z_1_1" type="xs:float"/>
        <xs:element name="z_2_M2" type="xs:float"/>
        <xs:element name="z_2_0" type="xs:float"/>
        <xs:element name="z_2_2" type="xs:float"/>
        <xs:element name="z_3_M3" type="xs:float"/>
        <xs:element name="z_3_M1" type="xs:float"/>
        <xs:element name="z_3_1" type="xs:float"/>
        <xs:element name="z_3_3" type="xs:float"/>
        <xs:element name="z_4_M4" type="xs:float"/>
        <xs:element name="z_4_M2" type="xs:float"/>
        <xs:element name="z_4_0" type="xs:float"/>
        <xs:element name="z_4_2" type="xs:float"/>
        <xs:element name="z_4_4" type="xs:float"/>
        <xs:element name="z_5_M5" type="xs:float"/>
        <xs:element name="z_5_M3" type="xs:float"/>
        <xs:element name="z_5_M1" type="xs:float"/>
        <xs:element name="z_5_1" type="xs:float"/>
        <xs:element name="z_5_3" type="xs:float"/>
        <xs:element name="z_5_5" type="xs:float"/>
        <xs:element name="z_6_M6" type="xs:float"/>
        <xs:element name="z_6_M4" type="xs:float"/>
        <xs:element name="z_6_M2" type="xs:float"/>
        <xs:element name="z_6_0" type="xs:float"/>
        <xs:element name="z_6_2" type="xs:float"/>
        <xs:element name="z_6_4" type="xs:float"/>
        <xs:element name="z_6_6" type="xs:float"/>
    </xs:sequence>

```



```

        <xs:element name="z_7_M7" type="xs:float"/>
        <xs:element name="z_7_M5" type="xs:float"/>
        <xs:element name="z_7_M3" type="xs:float"/>
        <xs:element name="z_7_M1" type="xs:float"/>
        <xs:element name="z_7_1" type="xs:float"/>
        <xs:element name="z_7_3" type="xs:float"/>
        <xs:element name="z_7_5" type="xs:float"/>
        <xs:element name="z_7_7" type="xs:float"/>
    </xs:sequence>
</xs:complexType>
<xs:complexType name="Zernikes8">
    <xs:complexContent>
        <xs:extension base="Zernikes7">
            <xs:sequence>
                <xs:element name="z_8_M8" type="xs:float"/>
                <xs:element name="z_8_M6" type="xs:float"/>
                <xs:element name="z_8_M4" type="xs:float"/>
                <xs:element name="z_8_M2" type="xs:float"/>
                <xs:element name="z_8_0" type="xs:float"/>
                <xs:element name="z_8_2" type="xs:float"/>
                <xs:element name="z_8_4" type="xs:float"/>
                <xs:element name="z_8_6" type="xs:float"/>
                <xs:element name="z_8_8" type="xs:float"/>
            </xs:sequence>
        </xs:extension>
    </xs:complexContent>
</xs:complexType>
<xs:complexType name="Zernikes9">
    <xs:complexContent>
        <xs:extension base="Zernikes8">
            <xs:sequence>
                <xs:element name="z_9_M9" type="xs:float"/>
                <xs:element name="z_9_M7" type="xs:float"/>
                <xs:element name="z_9_M5" type="xs:float"/>
                <xs:element name="z_9_M3" type="xs:float"/>
                <xs:element name="z_9_M1" type="xs:float"/>
                <xs:element name="z_9_1" type="xs:float"/>
                <xs:element name="z_9_3" type="xs:float"/>
                <xs:element name="z_9_5" type="xs:float"/>
                <xs:element name="z_9_7" type="xs:float"/>
                <xs:element name="z_9_9" type="xs:float"/>
            </xs:sequence>
        </xs:extension>
    </xs:complexContent>
</xs:complexType>
<xs:complexType name="Zernikes10">
    <xs:complexContent>
        <xs:extension base="Zernikes9">
            <xs:sequence>
                <xs:element name="z_10_M10" type="xs:float"/>
                <xs:element name="z_10_M8" type="xs:float"/>
                <xs:element name="z_10_M6" type="xs:float"/>
                <xs:element name="z_10_M4" type="xs:float"/>
                <xs:element name="z_10_M2" type="xs:float"/>
                <xs:element name="z_10_0" type="xs:float"/>
                <xs:element name="z_10_2" type="xs:float"/>
                <xs:element name="z_10_4" type="xs:float"/>
                <xs:element name="z_10_6" type="xs:float"/>
                <xs:element name="z_10_8" type="xs:float"/>
                <xs:element name="z_10_10" type="xs:float"/>
            </xs:sequence>
        </xs:extension>
    </xs:complexContent>
</xs:complexType>
<xs:complexType name="Zernikes11">
    <xs:complexContent>
        <xs:extension base="Zernikes10">
            <xs:sequence>
                <xs:element name="z_11_M11" type="xs:float"/>
                <xs:element name="z_11_M9" type="xs:float"/>
                <xs:element name="z_11_M7" type="xs:float"/>
            </xs:sequence>
        </xs:extension>
    </xs:complexContent>
</xs:complexType>

```

```
<xs:element name="z_11_M5" type="xs:float"/>
<xs:element name="z_11_M3" type="xs:float"/>
<xs:element name="z_11_M1" type="xs:float"/>
<xs:element name="z_11_1" type="xs:float"/>
<xs:element name="z_11_3" type="xs:float"/>
<xs:element name="z_11_5" type="xs:float"/>
<xs:element name="z_11_7" type="xs:float"/>
<xs:element name="z_11_9" type="xs:float"/>
<xs:element name="z_11_11" type="xs:float"/>
</xs:sequence>
</xs:extension>
</xs:complexContent>
</xs:complexType>
<xs:complexType name="Zernikes12">
  <xs:complexContent>
    <xs:extension base="Zernikes11">
      <xs:sequence>
        <xs:element name="z_12_M12" type="xs:float"/>
        <xs:element name="z_12_M10" type="xs:float"/>
        <xs:element name="z_12_M8" type="xs:float"/>
        <xs:element name="z_12_M6" type="xs:float"/>
        <xs:element name="z_12_M4" type="xs:float"/>
        <xs:element name="z_12_M2" type="xs:float"/>
        <xs:element name="z_12_0" type="xs:float"/>
        <xs:element name="z_12_2" type="xs:float"/>
        <xs:element name="z_12_4" type="xs:float"/>
        <xs:element name="z_12_6" type="xs:float"/>
        <xs:element name="z_12_8" type="xs:float"/>
        <xs:element name="z_12_10" type="xs:float"/>
        <xs:element name="z_12_12" type="xs:float"/>
      </xs:sequence>
    </xs:extension>
  </xs:complexContent>
</xs:complexType>
</xs:schema>
```

Index

- D -

description: 53

- F -

float 126

Endnotes 2... (after index)

Back Cover